

Revision 6

Standard Design Changes: Acceptable Technical Data

xx xxx 2021

General

Civil Aviation Authority (CAA) advisory circulars (ACs) contain guidance and information about standards, practices, and procedures that the Director has found to be an acceptable means of compliance with the associated rules and legislation.

Consideration will be given to other methods of compliance that may be presented to the Director. When new standards, practices, or procedures are found to be acceptable they will be added to the appropriate AC.

Purpose

This AC describes an acceptable means of compliance with Civil Aviation Rule Part 43 *General Maintenance Rules* by providing methods, techniques, and practices that are acceptable to the Director in the form of technical instructions which are acceptable technical data under Part 21, Appendix D(a)(6).

Related Rules

This AC relates specifically to Rule Part 43 *General Maintenance Rules*.

Change Notice

This revision makes the format consistent, amends Appendix 6 to include dual NAV/COM devices and adds the following new appendices:

- Appendix 15: Antenna installations
- Appendix 16: Installation of replacement LED lights
- Appendix 17: Installation of supplemental electronic carbon monoxide (CO) detectors
- Appendix 18: Installation of Angle of Attack systems for awareness only
- Appendix 19: Installation of ADS-B devices for awareness only

It also changes the order of some sections, in order to insert updated information.

~~This revision amends the title of the AC and incorporates the following appendices.~~

Published by
Civil Aviation Authority
PO Box 3555
Wellington 6140

Authorised by
DCE Aviation Safety

- ~~Appendix 2 : Installation of FAA TSO-C126 () ELTs~~
- ~~Appendix 13: Installation of Stand-alone ADS-B Systems~~
- ~~Appendix 14: Temporary Mounting of Lightweight Cameras~~

Cancellation Notice

This AC cancels AC43-14 Revision 5, dated 5 July 2019. 4 dated 10 June 2016.

Version History

History Log

Revision No.	Effective Date	Summary of Changes
0	16 November 1998	Initial issue of this AC.
1	07 October 2002	Provided examples of avionic major modifications in the definition of "Major Modification".
2	27 April 2007	Altered a number of references.
3	12 March 2008	Revised Appendix 2 to reflect the requirements for the installation of 406 MHz ELTs. The references to FAA AC 43.13-1A were revised to FAA 43.13-1B, and SAE-AS23190 supersedes MIL-S-23190E. The case of multi-sensor integrated systems that have all switching internal to the unit being considered directly coupled was clarified. Also added Appendix 12 for the installation of FLARM Situational Awareness equipment into gliders.
4	10 June 2016	Provided clarity around the use of this AC and information requirements to be forwarded to CAA.
5	05 July 2019	Amended the title of the AC, the numbering system, and incorporated the following appendices: <ul style="list-style-type: none"> • Updates to Appendix 2: Installation of FAA TSO-C126 ()¹ ELTs

¹ When a () is inserted after a TSO reference, it means that all versions of that TSO are allowed.

		<ul style="list-style-type: none"> • Appendix 13: Installation of Stand-alone ADS-B Systems • Appendix 14: Temporary Mounting of Lightweight Cameras.
6	Xx xxxx 2021	<p>Makes the format consistent.</p> <p>Amends Appendix 6 to include dual NAV/COM devices</p> <p>Adds the following new appendices:</p> <ul style="list-style-type: none"> • Appendix 15: Antenna installations • Appendix 16: Installation of replacement LED lights • Appendix 17: Installation of supplemental electronic carbon monoxide (CO) detectors • Appendix 18: Installation of Angle of Attack systems for awareness only • Appendix 19: Installation of ADS-B devices for awareness only <p>It also changes the order of some sections, in order to insert updated information.</p>

Table of Contents

Introduction	6
Applicability.....	6
General	6
Definitions	8
Acceptable Technical Data.....	10
6. Equipment Selection	10
7. Equipment Installation	10
8. Equipment Cooling.....	13
9. Antenna Location	13
10. Wiring and Wiring Practices	13
11. Weight and Balance	14
Electrical Load Analysis	14
Post-installation Testing.....	14
Modification Documentation	17
A1. APPENDIX 1—Replacement ‘Fit-Form-Function’ Equipment	19
A2. APPENDIX 2—Installation of FAA TSO-C126 () ELTs.....	22
A3. APPENDIX 3—Installation of ATC Mode 3/A Transponder with Mode C Altitude Reporting	27
A4. APPENDIX 4—Installation of Stand-alone GPS Equipment	31
A5. APPENDIX 5—Installation of Audio Panel and Intercoms	34
A6. APPENDIX 6—Installation of VHF Radio Communications.....	37
A7. APPENDIX 7—Installation of VHF Radio Navigation Receivers and Distance Measuring Equipment	40
A8. APPENDIX 8—Installation of Voltage Converters	43
A9. APPENDIX 9—Installation of ‘Non-Aeronautical’ Electronics Equipment	46

A10.	APPENDIX 10—Installation of 12VDC Electrical Distribution System for Gliders	49
A11.	APPENDIX 11—Removal of Avionics Systems	53
A12.	APPENDIX 12—Installation of Situation Awareness Equipment for Gliders	55
A13.	APPENDIX 13—Installation of Stand-alone ADS-B Systems.....	58
A14.	APPENDIX 14—Temporary Mounting of Lightweight Cameras	64
A15.	APPENDIX 15—Installation of a single mount antenna	68
A16.	APPENDIX 16—Installation of replacement LED lights	73
A17.	APPENDIX 17—Installation of supplemental electronic carbon monoxide (CO) detectors	76
A18.	APPENDIX 18—Installation of Angle of Attack (AoA) Sensors for awareness only	79
A19.	APPENDIX 19—Installation of ADS-B systems for awareness only	82

Introduction

1.1 All design changes to aircraft must be carried out in accordance with acceptable technical data. Acceptable technical data is listed in Part 21, Appendix D.

1.2 Part 21, Appendix D(a)(6) specifically identifies data published in an AC as acceptable technical data.

1.3 Please note that Appendix D(a) lists other acceptable technical data (than specified in this AC), including the possibility to have data approved by the Director under rule 21.505.

1.4 This AC provides acceptable technical data for standard design changes. Installers may find this AC useful for implementing some common, low-risk modifications to general aviation aircraft without having to approach the Director or a certificated Part 146 aircraft design organisation for further approval.

NOTE: When this AC is used for any purpose, all elements of the AC are to be considered and complied with in their entirety.

Applicability

2.1 This AC is applicable to unpressurised aircraft of less than 5700kg MCTOW and with a maximum certified seating capacity of less than 10 passenger seats, but only when:

- (a) The installation of the modification is not classified as a major modification by the LAME or appropriately authorised person in accordance with Part 43 (see AC43-9 Appendix A).
- (b) The data is not in conflict with the type certificate holder's data.

2.2 If a modification is not listed in one of the appendices, this AC does not apply.

NOTE: AC43-14 does not apply to light sport aircraft (LSA) which have been issued an airworthiness certificate under rule 21.201, as the certificate requires the LSA manufacturer to approve all changes to the type design.

General

3.1 This AC is divided into two parts:

- (a) The first part provides the general elements that must be addressed for all modifications conducted under this AC, noting that not all elements will be required in all cases. When an element is not required in a particular case, this AC expressly provides so.
- (b) The second part consists of a series of appendices which provide the specific elements that should be addressed in the particular types of modifications covered by this AC.

~~3.2 — Part 21, Appendix D, lists the types of technical data that are considered to be acceptable for modifications and repairs to products and their associated systems and components.~~

~~3.3 — Part 21, Appendix D (a)(6) states that data provided by the CAA in an AC is acceptable technical data.~~

~~3.4 — A major modification or repair is one that could potentially affect the safety of an aircraft or its occupants where, as a result of its embodiment, one or more of a series of incidents may occur. This AC does not apply to major modifications.~~

~~3.5 — This AC is intended as an enabler for installers of those modifications that are deemed low risk, where the requirement to involve a certificated Part 146 design organisation does not substantially add value to the certification process.~~

3.2 In general, this AC only includes minor design changes covering non-complex, non-integrated systems installed on a non-interference basis. Refer to sub-section 14.7 for more details.

3.3 It is important to note that if a particular modification cannot comply fully with requirements in this AC, then the modification is not covered and another means of acceptance or approval of the technical data must be sought.

3.4 Provided the modification is not classified as major and the data is not in conflict with the type certificate holder's data, this AC provides acceptable technical data, within specified limitations and conditions, for modifications covering the following equipment:

- (a) Replacement fit-form-function avionics systems.
- (b) FAA TSO-C126 () ELTs.
- (c) Transponder/encoder (noting that this excludes Mode S and ADS-B).
- (d) VFR GPS (noting that this excludes GPS units optimised for specialist applications such as agricultural aviation).
- (e) Audio and intercom.
- (f) VHF communication plus VHF radio navigation and DME.
- (g) Voltage converters.
- (h) Non-aeronautical electronics equipment.
- (i) 12VDC electrical distribution system for gliders.
- (j) Situation awareness equipment for gliders.
- (k) Removal of avionics equipment.
- (l) Installation of stand-alone ADS-B systems.
- (m) Temporary mounting of lightweight cameras.

- (n) Antenna installations.
- (o) Installation of replacement LED lights.
- (p) Installation of supplemental electronic carbon monoxide (CO) detectors.
- (q) Installation of Angle of Attack systems for awareness only.
- (r) Installation of ADS-B devices for awareness only.

Definitions

See also *Civil Aviation Rules Part 1* for other terms.

Fit-form-function in respect of avionics equipment, is equipment that:

- (a) is specified by a manufacturer to be a direct replacement for another item of equipment
- (b) utilises the same:
 - (1) mounting provisions
 - (2) wiring
 - (3) connectors, and
- (c) has an equivalent level of performance and certification.

NOTE: *Communication and navigation equipment must be the same level as defined in Part 91, Appendix A.9.*

NOTE: *Special attention must be paid to the software configuration and version to determine functionality equivalence.*

Major modification is defined in Civil Aviation Rule Part 1. When determining whether or not a modification to an aircraft, system, component, part, wiring, appliance or software is “major”, the criteria below should be considered:

- (a) What is the appreciable effect on weight?
- (b) What is the appreciable effect on balance?
- (c) What is the appreciable effect on structural strength?
- (d) What is the appreciable degradation of reliability or performance?
- (e) Interfaces and degree of integration with other systems?
- (f) What is the appreciable effect on operational characteristics of the product?
- (g) What is the change to the flight manual other than the addition of a supplement?
- (h) Whether it introduces or affects a function where the operating condition or a failure condition is catastrophic or hazardous? (i.e. incapacitating injury to any

occupant, structural collapse, loss of control, failure of motive power, or unintentional operation of, or inability to operate, any systems or equipment essential to the safety or operational function of the aircraft).

- (i) Whether it is mandated by an airworthiness directive or terminating action of an airworthiness directive?
- (j) Whether the change is accomplished by methods other than acceptable methods, techniques and practices or elementary operations?
- (k) Whether the change will be a significant change to primary structure or life limited parts?
- (l) Whether the change will affect the product's TSO?

Examples of a major modification include the installation of, or changes to:

- (a) penetration of pressure vessels such as antenna and doubler installations to pressurised areas
- (b) primary structural elements such as spars
- (c) HF radio transmitter systems
- (d) GPS/GNSS systems required for IFR operations
- (e) cockpit panels on rotorcraft approved for NVIS, or
- (f) any avionics modification that has the potential to interfere with critical systems, such as modifications to aircraft fitted with:
 - (1) FADEC (full authority digital engine control); or
 - (2) fly by wire systems.

Non-aeronautical electronics equipment for the purpose of this AC means electrical and electronic equipment that is:

- (a) not required by an airworthiness or rule requirement
- (b) suitable for installation and use in aircraft
- (c) installed on a no-hazard, no-interference basis.

Examples of non-aeronautical equipment are cellular telephones, audio entertainment systems, FM transceivers, and stand-alone flight monitoring/tracking devices. ~~or CD players.~~

Stand-alone installation in respect of an avionics installation means one where the equipment being installed is not interfaced with any other avionics systems or component, other than connection to an existing approved electrical power distribution system.

- (a) A stand-alone installation includes all components associated with the function being installed.
- (b) Examples:
 - (1) For a VHF installation it could include the transceiver, controller, antenna, rack and wiring.
 - (2) A major modification or a modification involving a change to a component or appliance is not to be considered a stand-alone installation.
 - (3) For an ADS-B system installation it could include the transponder, antenna, rack, remote control head, wiring and dedicated GNSS position source unit.

Transverse separation means the separation of the aircraft fuselage across the longitudinal axis.

Acceptable Technical Data

5.1 This AC provides acceptable technical data at the appendices for various installations that are generally not considered major modifications.

5.2 The appendices should be used in conjunction with the equipment manufacturer's data including:

- (a) installation manuals
- (b) installation and checkout manuals
- (c) operation and installation instructions, or
- (d) installation drawings.

6. Equipment Selection

6.1 Regardless of the equipment selected, all items must be appropriate for the aircraft and function, be fit for purpose and safe.

6.2 Equipment environmental specifications and qualifications must be appropriate for the type of aircraft and location it is being installed into. For example, RTCA DO-160 environmental qualification requires higher levels of vibration tolerance for helicopters than fixed wing. Check with the equipment manufacturer if in any doubt.

7. Equipment Installation

7.1 The equipment should be installed so that it will be adequately restrained throughout the flight envelope.

7.2 Care should also be taken to ensure that the installation will not interfere with any controls. If necessary, restraints should be installed at the rear of avionics racks to provide additional support.

7.3 The installation of equipment under the provisions of this AC must consider the overall human factors involved in the installation, including but not limited to:

- (a) Indicators and controls are clearly visible to the crew.
- (b) The new equipment or modified installation will not impair crew visibility.
- (c) The crew can operate controls required in flight from their normally seated position.
- (d) Misleading information must not be presented to the crew; the source of all data presented to the crew must be easily determined.
- (e) Readability of displays and indicators under varying light conditions must be considered.
- (f) Controls and switches must be clearly labelled and operate in accordance with the instinctive directions.

7.4 All installations must be carried out in accordance with the equipment manufacturer's installation instructions, the aircraft maintenance manual and the guidelines in FAA AC43.13-1B. The installation should conform to the following requirements:

- (a) Manufacturer-supplied or standard parts should be used.
- (b) If the equipment is not mounted in the standard aircraft radio rack, then the equipment mounting must be tested to ensure that the equipment will be restrained throughout the flight envelope and in emergencies.
- (c) Due to differences among various aircraft designs in flight and ground load factors, contact the aircraft manufacturer for the load factors required for a given model and location.
- (d) If the equipment or aircraft manufacturer's instructions do not provide guidance on the load factors, use the load factor values in Table 1 and Table 2 of this section.
- (e) A typical test load to be applied will be: Ultimate load factor (a number multiplied by $g=9.81$) x Mass of equipment installed. Where Limit load factor is specified, also multiply by a factor of safety of 1.5 to find the Ultimate load factor.
- (f) When testing structural loads, apply a load at the centre of gravity position of the equipment item by any suitable means to demonstrate that the attachment and structure can support the required loads. When no damage or permanent deformation occurs after 3 seconds of applied static load, the structure and

attachments are acceptable. Should permanent deformation occur after 3 seconds, modifications or reinforcements are required to the affected structure.

CAUTION: The aircraft and/or equipment can be damaged in applying static loads, particularly if a careless or improper procedure is used. It is recommended, whenever practicable, that static testing be conducted on a duplicate installation in a jig or mock-up which simulates the related aircraft structure. Static test loads may exceed the yield limits of the assemblies being substantiated and can result in partially sheared fasteners, elongated holes, or other damage which may not be visible unless the structure is disassembled. If the structure is materially weakened during testing, it may fail at a later date. Riveted sheet metal and composite laminate construction methods especially do not lend themselves to easy detection of such damage. Consult with a Part 146 Design Organisation if in any doubt.

Table 1: Items mounted inside the cabin

Direction	Ultimate Load Factor Aeroplane stall speed landing configuration (V _{so}) ≤ 45Kts	Ultimate Load Factor Aeroplane stall speed landing configuration (V _{so}) > 45Kts	Ultimate Load Factor Acrobatic	Ultimate Load Factor Rotorcraft
Sideward	3.0 g	4.5 g	4.5 g	8 g
Upward	3.0 g	3.0 g	4.5 g	4 g
Forward*	9.0 g	18.0 g	18 g	16 g
Downward	6.6 g	6.6 g	9.0 g	20 g
Aft	--	--		1.5 g

*When equipment mounting is located externally to one side, or forward of occupants, a forward load factor of 2.0g is sufficient for items inside the cabin.

Table 2: Items mounted outside of the cabin

Direction	Ultimate Load Factor - Aeroplane (non-acrobatic)	Ultimate Load Factor - Acrobatic	Ultimate Load Factor Rotorcraft
Sideward	3.0 g	1.5 g	2.0 g
Upward	3.0 g	4.5 g	1.5 g
Forward	9.0 g	9.0 g	2.0 g
Downward	6.6 g	9.0 g	5.25 g
Air flow direction	Refer to individual appendix "drag loads"		

(g) The above tables do not account for gust loads. Gust load factors will be unique to each airframe. These factors should be obtained from the OEM or with the

assistance of a Part 146 DO. These factors should be compared against those in Table 1 or 2 as applicable to determine the critical load factors for testing.

- (h) Where a modification is required to the aircraft structure to show compliance with paragraphs (c)-(f), the modification is to be carried out in accordance with the aircraft maintenance manual and the guidelines in FAA AC43.13-1B. For major modifications, a Part 146 aircraft design organisation must be used.

8. Equipment Cooling

8.1 The manufacturer's installation manual should be consulted with regards to any special cooling requirements for the equipment being installed. In particular, the heating effect of installing a number of items of equipment in close proximity, e.g. a radio stack, should be considered.

9. Antenna Location

9.1 If an antenna is being installed, the antenna should be installed in accordance with A15. APPENDIX 15—Installation of a single mount antenna of this AC.

~~9.1 If an antenna is being installed, the antennae should be located at:~~

- ~~(a) the aircraft manufacturer approved location; or~~
- ~~(b) a location determined in accordance with FAA AC43.13-2B Chapter 3; or~~
- ~~(c) where a location is not specified or cannot be determined under paragraphs (a) or (b), the following guidelines should be followed:~~
 - ~~(1) the antennae should not be located within 0.9m of each other~~
 - ~~(2) due to the sensitivity of the receiver, GPS antennas should not be located within 1.1m of a transmitter antenna.~~

~~9.2 Where an antenna is not installed in an approved location, suitable testing should be carried out to determine the suitability of the selected location. These provisions should include tests to ensure the satisfactory operation of the system being installed and a check for no interference between other avionics systems. A certificated Part 146 design organisation may be able to substantiate an antenna location if paragraph 9.1 cannot be complied with (e.g. due to proximity with existing antenna).~~

~~9.3 Refer to Appendix 2 of this AC for the installation of FAA TSO C126 () ELT antennas, and AC43-11 for guidance on the installation of AELS antennas.~~

10. Wiring and Wiring Practices

10.1 All electrical wiring and wiring practices should be conducted in accordance with the applicable aircraft type wiring practices documentation, the installed equipment

manufacturer documentation, or if not available SAE AS 50881F, FAA AC43.13-1B chapter 11.

11. Weight and Balance

11.1 The change in weight and balance, which results from the change, is to be amended in accordance with AC43-2, *Aircraft Empty Weight and Empty Weight Centre of Gravity - Forms CAA 2102 and CAA 2173*.

11.2 When discrete equipment is installed or removed, the weight and balance records should be revised to reflect the change.

11.3 Only installation materials such as interconnecting wire that is distributed through the aircraft may be considered 'negligible' provided the weight change due to those materials is less than 0.1% of the aircraft maximum weight.

Electrical Load Analysis

12.1 An electrical load analysis (ELA) is to be carried out (refer AC21-11 & 91-23, *Electrical Load Analysis*) by the installer to determine that:

- (a) the electrical load is less than rated % of the maximum continuous operating rating of the power generating system, and
- (b) the derated battery capacity is sufficient to operate emergency systems for the required time determined for the aircraft, following a failure the aircraft's power generating system or as required for the aircraft's operations.

Post-installation Testing

13.1 The installation is to be tested in accordance with the checkout procedures in the manufacturer's manuals and the applicable requirements of Part 43.

13.2 The tests should include, but are not limited to ensuring the following:

- (a) The system operates correctly in accordance with the manufacturer's specifications.
- (b) There is no interference between systems (see below).
- (c) The equipment is suitable for the intended purpose.
- (d) The installation meets the relevant structural requirements (as defined by the airworthiness design standards of the aircraft's original certification basis as it appears in the type certificate data sheet (TCDS)) and will be restrained throughout the flight envelope. The installation should not significantly affect crashworthiness, canopy jettison and emergency exit. Special consideration is necessary for equipment installed at locations above or behind occupants.

- (e) The system does not pose any HMI issues to the crew. The installation must take into account arrangement, visibility and interferences with other displays or equipment.
- (f) There is no effect on the aircraft's magnetic compass system.
- (g) The installation does not interfere with any controls (including flight controls, engine controls, equipment, instruments and switches). These checks should include but are not limited to:
 - (1) a check of all flying controls for full and free movement, and
 - (2) a check of engine control levers to ensure that there is no restriction throughout their range of movement.

13.3 Check for non-interference

13.3.1 Part of the post-installation checks should include a test to determine that there is no interference between avionics/electrical systems.

13.3.2 Consider these factors when determining the extent of the no-interference check:

- (a) Type of system(s) being installed.
- (b) Degree of complexity of the systems interconnected.
- (c) Physical location of equipment.
- (d) Cable routing.
- (e) Antenna locations.
- (f) Consequence of any interference on the ability to safely operate the aircraft and systems.

13.3.3 For systems being installed in accordance with this AC, a simplified no-interference check should be acceptable. A simplified check to determine no-interference between avionics systems should incorporate the following guidelines with the test procedures and the results to be documented:

- (a) All avionics systems should be turned ON and the AELS should be ARMED.
- (b) Each of the following items of equipment should be operated in sequence and all other systems checked for any interference:
 - (1) RF transmitters (any equipment that emits RF, such as communication radios, bluetooth, cellular and wifi-transmitting equipment).
 - (2) Equipment with a high voltage switched power source such as a strobe.
 - (3) Equipment containing motors or generators.

- (c) In addition, GPS equipment should be specifically checked for interference when transmitting on each VHF for ~~30~~ 20-seconds on each of the following frequencies.

Table 3: VHF GPS interference frequencies

For VHF Radios with 25 kHz Channel Spacing			
121.15 MHz	121.22 MHz	131.22 MHz	131.30 MHz
121.17 MHz	121.25 MHz	131.25 MHz	131.32 MHz
121.20 MHz	131.20 MHz	131.27 MHz	131.35 MHz
For VHF Radios with 8.33 kHz channel spacing, include the following frequencies:			
121.185 MHz	130.285 MHz	121.190 MHz	131.290 MHz

- (1) ~~121.150 MHz~~
 (2) ~~121.175 MHz~~
 (3) ~~121.200 MHz~~
 (4) ~~131.250 MHz~~
 (5) ~~131.275 MHz~~
 (6) ~~131.300 MHz~~

- (d) When looking for interference, the following should be considered:

- (1) Is there any audible interference in the aircraft audio, intercom or communication systems?
- (2) Is there any observable change in navigation information including:
 - (i) heading pointers
 - (ii) to/from indications
 - (iii) deviation signals
 - (iv) validity flags
 - (v) warning/message annunciations
 - (vi) loss of navigation information
 - (vii) loss of integrity
- (3) is there any inadvertent operation or failure-to-operate of any system?

- (e) A validation flight may be required to check some systems for interference effects e.g. an existing autopilot.

NOTE: Flight validation checks should only be carried out after ground tests have been completed satisfactorily and in accordance with the rules.

13.3.4 If there is any doubt about the acceptability of an aircraft system to successfully complete checks for no-interference, the details of the installation and problem should be referred to CAA's **Certification Airworthiness Unit**.

Modification Documentation

14.1 The modification is to be documented by completing form CAA043-01 *Modification Record* and adding this to the aircraft maintenance records.

14.2 The aircraft modification section of the maintenance records must be updated to reflect the incorporation of the modification.

14.3 A copy of the form CAA043-01 *Modification Record* along with the attachments required must be sent to CAA within 28 days of the certification of release to service being issued. Forward to **certification@caa.govt.nz** ~~airworthiness@caa.govt.nz~~ or **Product Certification Unit, Airworthiness Unit**, Civil Aviation Authority, P.O. Box 3555, Wellington 6140.

14.4 Airworthiness directives may impact on the major modification determination and must be reviewed to determine whether any are applicable to the system being installed or the areas of the aircraft to be modified are subject to any airworthiness directives. Any outstanding airworthiness directives are to be actioned.

14.5 Certification

14.5.1 The certification of release to service in respect of modifications embodied using this AC as acceptable technical data, must be issued by an appropriately qualified person in accordance with Part 43.

14.5.2 It is important to note that this AC only provides for the acceptance of the technical data (in relation to Part 21), and that **it does not extend the certification privileges granted** by any specific aircraft maintenance engineer licence category, Part 145 authorisation, or certificate of maintenance approval.

14.5.3 In the case of a certificated Part 145 maintenance organisation authorisation, the company exposition will detail the privileges of each authorisation.

14.5.4 Prior to exercising privileges of an AME licence in any category all licence holders must ensure that an appropriate rating is held and that they are familiar with the task to be undertaken.

14.5.5 For example, a radio rated engineer must be familiar with the airframe structural implications of installing an antenna prior to fitment in a specific location.

14.6 Form CAA 2129 action

14.6.1 If you are required to amend form CAA 2129, where a change is made in accordance with this AC, the Mod Ref column of the form CAA 2129 adjacent to the entry for the equipment being installed or removed should provide a reference to AC43-14 and the appropriate appendix.

14.7 Integrated systems

14.7.1 Equipment that combines two or more functions into a single unit is now available. These systems may not be installed using the provisions of this AC unless specifically identified as acceptable and expressly listed in the appendices.

14.7.2 Units that interface with multiple systems may not be installed using the provisions of this AC unless specifically identified as acceptable and expressly listed in the appendices.

14.7.3 This AC does not apply to complex or multi-function systems which may require system safety assessments, including analysis of common modes of failure, cascading failures and single point failures to be addressed as part of a design approval process.

14.8 Instructions for continued airworthiness

14.8.1 For all equipment installed, conduct a review and/or an assessment of the requirements for ongoing maintenance to ensure continued airworthiness.

14.8.2 Generate and issue instructions for continued airworthiness, to include maintenance actions, inspections and intervals as required.

14.8.3 These requirements are to be generated as instructions for continued airworthiness (ICA) and added to the aircraft's maintenance schedule.

14.9 Flight manual supplements / Pilot guides

14.9.1 For all equipment installed, conduct a review and/or an assessment of the aircraft flight manual (AFM) operational limitations, procedures and performance sections to ensure no changes are required.

14.9.2 Changes to certified aircraft operating limitations, performance and procedures are considered major design changes (e.g. change from VFR to IFR, removal or addition of limitations, change to flight envelope, etc.) and are beyond the scope of this AC.

14.9.3 Information contained in a pilot guide, user manuals or operating instructions supplied by the equipment manufacturer for the installed equipment may be inserted as a supplement to the AFM or pilot operating handbook (POH) to ensure continued safe operations.

A1. APPENDIX 1—Replacement 'Fit-Form-Function' Equipment

A1.1 Description

A1.1.1 Replacement of existing avionics equipment with equipment of identical fit, form and function.

A1.2 Applicability

A1.2.1 All limitations of **sub-section** paragraph 2.1 apply.

A1.2.2 **Sections** Paragraphs 1 to 14 of this AC apply.

A1.3 General

A1.3.1 Replacement fit-form-function equipment must:

- (a) perform an identical function to the equipment being replaced
- (b) not alter the existing approved aircraft maintenance requirements
- (c) be of an equivalent approval level as defined in Part 91, Appendix A.9, **and**
- (d) be specified by the equipment manufacturer as being a direct replacement for the equipment being removed.

A1.3.2 Replacement fit-form-function installations must utilise where applicable the existing:

- (a) equipment rack or mounting provisions
- (b) wiring, **and**
- (c) interface with existing systems.

A1.4 Technical instructions

A1.4.1 Ensure the aircraft is safe for servicing.

A1.4.2 Open circuit breakers or remove fuses as required to isolate power from the system(s) to be replaced.

A1.4.3 Remove access panels, etc. as required in accordance with the aircraft manufacturer's maintenance manual.

A1.4.4 Verify that the circuit breaker or fuse rating from the equipment to be removed is appropriate for the new equipment. If the fuse or circuit breaker rating is not appropriate for the new equipment, the modification is no longer the replacement of form, fit and function equipment and capable of approval under the provisions of Appendix 1 to this AC.

A1.4.5 Remove the equipment(s) to be replaced. Existing associated wiring and rack(s) or mounting provisions are to be retained.

A1.4.6 Install the replacement equipment(s) in accordance with the manufacturer's installation instructions and the aircraft maintenance manual in the space vacated in **sub-section paragraph** A1.4.5. The existing rack(s) or mounting provisions are to be utilised.

A1.4.7 Replace the access panels removed in **sub-section paragraph** A1.4.3 in accordance with the aircraft manufacturer's maintenance manual.

A1.4.8 Close the circuit breakers or reinstall the fuses removed in **sub-section paragraph** A1.4.2.

~~A1.4.9 Carry out a functional test of the installed system and all other disturbed systems in accordance with the applicable Part 43 and the manufacturer's installation/operation instructions. A check is to be carried out to ensure that there is no interference between avionics systems, that there is no effect on the aircraft compass system and that there is no interference with the aircraft flight controls.~~

~~A1.4.10 Amend the aircraft's weight and balance records (refer AC43-2).~~

~~A1.4.11 Complete or update ELA, retain copy with aircraft and submit copy with documentation (refer AC21-11 & 91-23).~~

~~A1.4.12 Amend the aircraft's form CAA 2129 if necessary (refer AC43-10).~~

~~A1.4.13 Generate and issue instructions for continued airworthiness (refer paragraph 14.8).~~

~~A1.4.14 Insert the equipment operating instructions in the AFM/POH (refer paragraph 14.9).~~

~~A1.4.15 Complete form CAA043-01 *Modification Record* and process as described in paragraph 14 of this AC.~~

~~A1.4.16 Make a certified statement of release to service in accordance with rule 43.105, detailing the work carried out and conformity with Appendix 1 of this AC.~~

A1.5 Post-Installation testing

A1.5.1 Carry out a functional test of the installed system in accordance with the manufacturer's installation/operations manual to determine satisfactory operation of the installed equipment. Checks are also to be carried out to determine satisfactory operation of all disturbed systems, that there is no interference between avionics systems, that there is no effect on the aircraft compass system and that there is no interference with the aircraft flight controls.

A5.5.2 For aircraft approved for night operations, ensure that the equipment lighting is satisfactory and that there are no unwanted reflections present.

A1.6 Manuals

A1.6.1 Generate and issue instructions for continued airworthiness (refer section 14.8, above).

A1.6.2 Insert the equipment operating instructions in the AFM/POH (refer section 14.9 of this AC).

A1.7 Certification and release to service

A1.7.1 Amend the aircraft's weight and balance records (refer AC43-2, *Aircraft Empty Weight and Empty Weight Centre of Gravity - Forms CAA 2102 and CAA 2173*).

A1.7.2 Complete or update ELA, retain copy with aircraft and submit copy with documentation (refer AC21-11 & 91-23).

A1.7.3 Amend the aircraft's form CAA 2129 if necessary (refer AC43-10, *Aircraft radio station - Form CAA 2129*).

A1.7.4 Complete form CAA043-01 *Modification Record*, and process as described in section 14 of this AC.

A1.7.5 Make a certified statement of release to service in accordance with rule 43.105, detailing the work carried out and conformity with Appendix 1 of this AC.

A2. APPENDIX 2—Installation of FAA TSO-C126 () ELTs

A2.1 Description

A2.1.1 Installation of FAA TSO-C126 ()1 ELTs including the associated remote switch/monitor and antenna.

A2.2 Applicability

A2.2.1 All limitations of **sub-section** paragraph 2.1 apply.

A2.2.2 **Sections** Paragraphs 1 to 14 of this AC apply.

A2.3 General

A2.3.1 Part 91, Appendix A.15 (a), requires that all ELTs installed after 22 November 2007 must meet the requirements of TSO-C126 ()**Error! Bookmark not defined.**

A2.3.2 This equipment should be installed in accordance with the requirements of the following:

- (a) The manufacturer's installation instructions.
- (b) Any airworthiness directives applicable to the aircraft type (e.g. DCA/HELI/3).
- (c) AC43-11, **Aircraft emergency locator systems**.

A2.4 Technical instructions

A2.4.1 Register the new ELT with RCCNZ and advise them of the hex code for the beacon prior to return to service. Proof of the registration is required for completion of the modification.

A2.4.2 Ensure the aircraft is safe for servicing.

A2.4.3 Remove access panels etc. as required in accordance with the aircraft manufacturer's maintenance manual.

A2.4.4 If an existing ELT is to be removed:

- (a) Open the ELT circuit breaker or remove the ELT fuse, as required, to isolate power from the existing ELT.
- (b) Remove the existing ELT and antenna (if not compatible with the new ELT), remote switch/monitor (if installed), ELT mounting tray and wiring.
- (c) Verify that any wiring that is to be re-used for the new ELT installation is of a type acceptable per FAA AC43.13-1B, Chapter 11, is in good condition, and is correctly installed.

A2.4.5 Install the ELT as follows:

- (a) Determine a suitable location for the ELT. The ELT should be located.

- (1) Where the ELT can be mounted to primary structure.
 - (2) Where the probability of damage in an accident or impact is minimised.
 - (3) For fixed and deployable automatic ELTs, as far as practicable.
 - (4) The distance between the ELT and the antenna is the least practicable.
 - (5) To prevent inadvertent operation of the crash activation sensor.
 - (6) With the axis orientated to sense a primary crash pulse in accordance with the ELT manufacturer's instructions. In particular, check that any AF model, e.g. Artex ME406 or Kannad Compact fitted in any helicopter is oriented / installed at 45 degrees. An AF-H must be a horizontal or vertical installation.
 - (7) Where the risk of a transverse separation severing the antenna cable is minimised. Transverse separations are likely to occur at production joints in the structure; the antenna cable must not cross these locations.
- (b) Install the ELT mounting tray at the location determined in **sub-section paragraph A2.4.5(a)**:
- (1) The installation is to be carried out in accordance with the manufacturer's installation instructions, the aircraft maintenance manual and the guidelines in FAA AC43.13-1B.
 - (2) The installation should conform to the following requirements.
 - (i) The ELT must be mounted to primary load-carrying structure such as trusses, bulkheads, longerons or floor beams (not aircraft skin) in such a manner that it does not degrade the aircraft structural capability. For aircraft using composite technology, standard composite structural techniques may be used to attach the equipment to the moulded structure.
 - (ii) Manufacturer-supplied or standard parts should be used.
 - (iii) When a force of 450 newtons (100 lbf) is applied to the mount in the most flexible direction there is no static deflection greater than 2.5mm (0.1 inch) relative to a section of adjacent structure located between 0.3m (1 foot) and 1.0m (3 feet) from the mount site.
 - (iv) Where a stiffening modification is required to the aircraft structure to show compliance with **sub-section paragraph A2.4.5(b)(2)(iii)**, the modification is to be carried out in accordance with the aircraft maintenance manual and the guidelines in FAA AC43.13-1B.
 - (v) The installed transmitter should be able to support a 100 G load in the plus and minus directions of the three principle axes of the aircraft. For example: for an ELT weighing 0.9kg (2 lb), this is a load of 900 newtons (200 lb) in any direction.

- (vi) Install a placard externally adjacent to the ELT installation which readily and clearly identifies the ELT location.

A2.4.6 Install the ELT remote switch/monitor assembly as follows:

- (a) Determine a suitable location for the remote switch/monitor assembly which must be located in a position which is accessible and viewable by the pilot from his/her normally seated position.
- (b) Install the ELT remote switch/monitor assembly in the location determined in **sub-section paragraph A2.4.5(a)**, in accordance with the manufacturer's installation instructions, the aircraft maintenance manual and the guidelines in FAA AC43.13-1B.

A2.4.7 Install the ELT antenna **in accordance with Appendix A15.**

- ~~(a) Determine a suitable location for the ELT antenna using the following criteria.~~
 - ~~(1) The ELT antenna should be located on the upper fuselage and not less than the manufacturer's recommended distance from other antennas.~~
 - ~~(i) In any case, the ELT antenna is not to be located less than 0.6m (24 inches) from other VHF antennas.~~
 - ~~(2) The ELT antenna should be located as close as possible to the ELT transmitter and preferably where the aircraft structure can provide some protection (particularly the antenna base) during a crash sequence. When installing an antenna near a structural element, take care to avoid the structure shrouding the antenna or causing excessive voltage standing wave ratio (VSWR) degradation.~~
 - ~~(i) Always check the VSWR after installation. The VSWR should be less than 2:1 and must not exceed 3:1.~~
 - ~~(3) The ELT antenna should be located so as to be vertically polarised.~~
 - ~~(i) The antenna location must ensure that the routing of the ELT transmitter to antenna coaxial cable does not cross any fuselage production joints and should avoid any other location where a transverse separation is likely.~~
 - ~~(ii) If possible, do not install the antenna cable so that it passes through any bulkhead or similar structure.~~
 - ~~(4) If the ELT antenna is mounted internally in the aircraft, the antenna is to be insulated from metal parts and exposed to an 'electronic' window of at least 0.3 m (1 foot) square.~~
- ~~(b) Install the ELT antenna in the location determined above, in accordance with the manufacturer's installation instructions, the aircraft maintenance manual and the guidelines in FAA AC43.13-2B Chapter 3.~~

- ~~(1) The ELT antenna should be capable of supporting a 100 G load in the plus and minus directions of the three principle axis of the aircraft.~~

A2.4.8 If required, install and placard a suitably rated circuit breaker or fuse.

- (a) Interconnect the ELT transmitter, remote switch/monitor, antenna and any other associated components in accordance with the manufacturer's installation instructions using the manufacturer-supplied loom where applicable. If the loom is to be locally manufactured, wire acceptable per FAA AC43.13-1B or equivalent is to be utilised.
- (b) Ensure that the transmitter-antenna coaxial cable is fitted with vibration proof, radio frequency connectors on each end with sufficient excess cable looped at each end, to tolerate some aircraft deformation in a crash without severing it. An excess cable loop held with no more than four small frangible ties will provide a stress relief point for the cable. It is also recommended that the antenna cable be covered with a fire-resistant sleeve.

A2.4.9 If the aircraft is fitted with an ELT that accepts an external position input and the aircraft has a GNSS receiver that has an output compatible with the ELT, it is strongly recommended that the GNSS be connected to the ELT.

- (a) Install the interface between the GNSS and the ELT in accordance with the manufacturer's instructions.
- (b) If the wire loom is to be locally manufactured, wire acceptable per FAA AC43.13-1B or equivalent is to be utilised.
- (c) The wire routing and installation must meet the requirements of FAA AC43.13-1B, Chapter 11.

A2.4.10 If the ELT installation is fitted with a configuration module (usually adjacent to the ELT connector), install the module in accordance with the manufacturer's instructions.

A2.4.11 Replace the access panels removed in **sub-section** paragraph A2.4.3 in accordance with the aircraft manufacturer's maintenance manual.

A2.4.12 Close the ELT circuit breaker or install the fuse.

A2.5 Post-Installation testing

A2.5.1 Verify the ELT is transmitting the correct identification code. This will usually require the use of an ELT system tester.

A2.5.2 The configuration data stored in the configuration module must be verified as being correct for that particular aircraft.

- (a) Verify the programming configuration module data is correct, and update the data as necessary, in accordance with the manufacturer's instructions.

- (b) If the data is not correct, data in the ELT will be over-written by data from the programming configuration module when it is connected, resulting in an incorrectly configured ELT.
- (c) Carry out a functional test of the ELT in accordance with Part 43, Appendix F, the AC43-11, and the manufacturer's installation/operation instructions.
- (d) Checks are also to be carried out to determine satisfactory operation of all disturbed systems, that there is no interference between avionics systems, no effect on the aircraft compass.

A2.6 Manuals

A2.6.1 Generate and issue instructions for continued airworthiness (refer section 14.8).

A2.6.2 Insert the equipment operating instructions in the AFM/POH (refer section 14.9).

A2.7 Certification and release to service

A2.7.1 Review the RCCNZ beacon registration documentation and verify the ELT is correctly registered.

A2.7.2 Amend the aircraft's weight and balance records (refer AC43-2).

A2.7.3 Complete or update ELA, retain copy with aircraft and submit copy with documentation (refer AC21-11 & 91-23).

A2.7.4 Amend the aircraft's form CAA 2129 if necessary (refer AC43-10).

~~A2.5.5 Generate and issue instructions for continued airworthiness (refer paragraph 14.8).~~

~~A2.5.6 Insert the equipment operating instructions in the AFM/POH (refer paragraph 14.9).~~

A2.7.5 Complete form CAA043-01 *Modification Record* and process as described in section paragraph 14 of this AC.

A2.7.6 Make a certified statement of release to service in accordance with rule 43.105 as well as detailing the work carried out and conformity with Appendix 2 of this AC.

A3. APPENDIX 3—Installation of ATC Mode 3/A Transponder with Mode C Altitude Reporting

A3.1 Description

A3.1.1 Installation of an FAA TSO-C74 (or equivalent) transponder and/or a TSO-C88 altitude encoder.

A3.2 Applicability

A3.2.1 All limitations of **sub-section paragraph 2.1** apply.

A3.2.2 **Sections Paragraphs** 1 to 14 of this AC apply.

A3.3 General

A3.3.1 Part 91, Appendix A.22 (1), requires that all Mode 3/A transponders meet the requirements of TSO-C74.

A3.3.2 Part 91, Appendix A.23, requires that each altitude encoder meets the requirements of TSO-C88.

A3.3.3 Appendix 3 to this AC is divided into two parts.

- (a) Part A – Installation of a transponder
- (b) Part B – Installation of an altitude encoder

A3.4 Technical instructions – Part A (Installation of a Mode 3/A transponder)

A3.4.1 Ensure the aircraft is safe for servicing.

A3.4.2 Remove access panels etc. as required in accordance with the aircraft manufacturer's maintenance manual.

A3.4.3 If an existing transponder is to be removed:

- (a) Open the transponder circuit breaker or remove the transponder fuse, as required, to isolate power from the existing transponder.
- (b) Remove the existing transponder, mounting tray, antenna and wiring as required.

A3.4.4 Install the transponder as follows:

- (a) If the transponder is being installed in a new location, determine a suitable location for the transponder. The transponder should be located in a position which is viewable and accessible to the pilot from his/her normally seated position. The preferred location is a standard aircraft manufacturer-installed avionics rack.
- (b) Install the transponder mounting tray at the location determined in **sub-section paragraph A3.4.4(a)**. The installation is to be carried out in accordance with the

manufacturer's installation instructions, the aircraft maintenance manual and the guidelines in FAA AC43.13-1B. The installation should conform to the following requirements.

- (1) Manufacturer-supplied or standard parts should be used.
- (2) The transponder mounting should be tested to ensure that the transponder and rack will be restrained throughout the flight envelope.
- (3) Where a modification is required to the aircraft structure to show compliance with **sub-section paragraph** A3.4.4(b)(2), the modification is to be carried out in accordance with the aircraft maintenance manual and the guidelines in FAA AC43.13-1B.

A3.4.5 Install the transponder antenna **in accordance with Appendix 15 of this AC.**

~~Install the transponder antenna as follows:~~

- ~~(a) Determine an approved location for the transponder antenna in accordance with FAA AC43.13-2B or the aircraft manufacturer's instructions. The antenna should not be located within 0.9m of any other antenna.~~
- ~~(b) Install the transponder antenna in the location determined in paragraph A3.4.5(a), in accordance with the manufacturer's installation instructions, the aircraft maintenance manual and the guidelines in FAA AC43.13-1B. The transponder antenna installation should be tested to ensure that it will be restrained throughout the flight envelope.~~

A3.4.6 Install and placard a suitably rated circuit breaker or fuse.

A3.4.7 Interconnect the transponder, altitude encoder and antenna in accordance with the manufacturer's installation instructions. Wire listed in FAA AC43.13-1B, Chapter 11 or equivalent is to be utilised.

A3.4.8 Replace the access panels removed in **sub-section paragraph** A3.4.2 in accordance with the aircraft manufacturer's maintenance manual.

A3.4.9 Close the transponder circuit breaker or install the fuse.

A3.4.10 Carry out a functional test of the transponder in accordance with Part 43, Appendix E, and the manufacturer's installation/operation instructions. A functional test of the transponder/altitude encoder system should be carried out in accordance with Part 43, Appendix D.3, and the manufacturer's installation/operation instructions. Checks are also to be carried out to determine satisfactory operation of all disturbed systems, that there is no interference between avionics systems, no effect on the aircraft compass system and that there is no interference with the aircraft flight controls.

A3.4.11 Amend the aircraft's weight and balance records (refer AC43-2).

A3.4.12 Complete or update ELA, retain copy with aircraft and submit copy with documentation (refer AC21-11 & 91-23).

- A3.4.13 Amend the aircraft's form CAA 2129 if necessary (refer AC43-10).
- A3.4.14 Generate and issue instructions for continued airworthiness (refer **sub-section paragraph 14.8**).
- A3.4.15 Insert the equipment operating instructions in the AFM/POH (refer **sub-section paragraph 14.9**).
- A3.4.16 Complete form CAA043-01 *Modification Record* and process as described in **section paragraph 14** of this AC.
- A3.4.17 Make a certified statement of release to service in accordance with rule 43.105, detailing the work carried out and conformity with Appendix 3 of this AC.

A3.5 Technical instructions – Part B (Installation of a Mode C altitude encoder)

- A3.5.1 Ensure the aircraft is safe for servicing.
- A3.5.2 Remove access panels etc. as required in accordance with the aircraft manufacturer's maintenance manual.
- A3.5.3 If an existing altitude encoder is to be removed:
- (a) Open the encoder circuit breaker or remove the encoder fuse, as required, to isolate power from the existing encoder.
 - (b) Remove the existing encoder, mounting provisions, and static connections as required. Ensure any unused static lines are blanked and stowed in such a manner so as to prevent a new low point being introduced in the aircraft static system.
- A3.5.4 Install the altitude encoder as follows:
- (a) If the encoder is being installed in a new location, determine a suitable location for the encoder. The encoder should be located in a position which is accessible to the aircraft static lines and will not introduce a new low point in the aircraft static system.
 - (b) Install the encoder at the location determined in **sub-section paragraph A3.5.4(a)**. The installation is to be carried out in accordance with the manufacturer's installation instructions, the aircraft maintenance manual and the guidelines in FAA AC43.13-1B. The installation should conform to the following requirements.
 - (1) Manufacturer-supplied or standard parts should be used.
 - (2) The encoder installation should be tested to ensure that the encoder will be restrained throughout the flight envelope.
 - (3) Where a modification is required to the aircraft structure to show compliance with **sub-section paragraph A3.5.4(b)(2)**, the modification is

to be carried out in accordance with the aircraft maintenance manual and the guidelines in FAA AC43.13-1B.

- (c) The encoder is to be connected to the aircraft static system in accordance with the manufacturer's installation instructions using manufacturer-approved connections. No new low point is to be introduced in the aircraft static system.
- (d) Install and placard a suitably rated circuit breaker or fuse.
- (e) Interconnect the altitude encoder and transponder in accordance with the manufacturer's installation instructions. Wire listed in FAA AC43.13-1B, Chapter 11 or equivalent is to be utilised.
- (f) Replace the access panels removed in sub-section paragraph A3.5.2 in accordance with the aircraft manufacturer's maintenance manual.
- (g) Close the altitude encoder circuit breaker or install the fuse.
- (h) Carry out a leak test of the aircraft static system in accordance with Part 43, Appendix D.1.
- (i) Carry out a functional test of the transponder/encoder system in accordance with Part 43, Appendix D.3, and the manufacturer's installation/operation instructions. Checks are also to be carried out to determine satisfactory operation of all disturbed systems, that there is no interference between avionics systems, no effect on the aircraft compass system and that there is no interference with the aircraft flight controls.
- (j) Amend the aircraft's weight and balance records (refer AC43-2).
- (k) Complete or update ELA, retain copy with aircraft and submit copy with documentation (refer AC21-11 & 91-23).
- (l) Amend the aircraft's form CAA 2129 if necessary (refer AC43-10).
- (m) Generate and issue instructions for continued airworthiness (refer sub-section paragraph 14.8).
- (n) Insert the equipment operating instructions in the AFM/POH (refer sub-section paragraph 14.9).
- (o) Complete form CAA043-01 *Modification Record* and process as described in section paragraph 14 of this AC.
- (p) Make a certified statement of release to service in accordance with rule 43.105, detailing the work carried out and conformity with Appendix 3 of this AC.

A4. APPENDIX 4—Installation of Stand-alone GPS Equipment

A4.1 Description

A4.1.1 Installation of a stand-alone GPS system used for en route VFR navigation, or as an ADS-B system external GNSS position source; noting that this specifically excludes GPS units optimised for specialist applications, such as agriculture operations.

A4.2 Applicability

A4.2.1 All limitations of **sub-section paragraph** 2.1 apply.

A4.2.2 **Section** paragraphs 1 to 14 of this AC apply.

A4.3 General & Limitations

A4.3.1 Appendix 4 to this AC provides installation instructions for stand-alone GPS systems used for en-route, VFR navigation only, noting that this specifically excludes GPS units optimised for specialist applications, such as agriculture operations. The GPS deviation signal is not to be switched to a remote indicator or coupled to an autopilot. The GPS deviation signal may be directly coupled to a dedicated remote indicator.

A4.3.2 An ADS-B system-dedicated external GNSS position source may only be installed in accordance with this Appendix 4 in conjunction with Appendix 13 of this AC.

A4.3.3 GPS systems installed for other purposes require approval, via either a form CAA337 or supplemental type certificate, and are beyond the scope of this AC.

A4.4 Technical Instructions

A4.4.1 Ensure the aircraft is safe for servicing.

A4.4.2 Remove access panels etc. as required in accordance with the aircraft manufacturer's maintenance manual.

A4.4.3 Install the GPS as follows:

- (a) Determine a suitable location for the GPS. The GPS should be located in a position which is viewable and accessible to the pilot from his/her normally seated position. The installed GPS should not:
 - (1) restrict access to or view of any control, display or indicator
 - (2) restrict movement of the flight controls
 - (3) interfere with the pilot's vision along the flight path, or
 - (4) restrict pilot/passenger egress.
- (b) Install the GPS at the location determined in **sub-section paragraph** A4.4.3(a). The installation is to be carried out in accordance with the manufacturer's installation instructions, the aircraft maintenance manual and the guidelines in FAA AC43.13-1B. The installation should conform to the following requirements.
 - (1) Manufacturer-supplied or standard parts should be used.

- (2) If a 'non-standard' method of installation is utilised, for example: velcro, the manufacturer's recommended procedures are to be followed.
- (3) The GPS mounting should be tested to ensure that it will be restrained throughout the flight envelope.
- (4) Where a modification is required to the aircraft structure to show compliance with **sub-section paragraph A4.4.3(b)(3)**, the modification is to be carried out in accordance with the aircraft maintenance manual and the guidelines in FAA AC43.13-1B.

A4.4.4 If required, install a remote GPS antenna **in accordance with Appendix 15 of this AC.**

~~If required, install a remote GPS antenna as follows:~~

- ~~(a) Determine a suitable location for the GPS antenna on the upper fuselage. The antenna should not be located within 1.1m of any other antenna. Particular care should be taken to ensure that at least the minimum separation is maintained between the GPS antenna and VHF communications and ELT antennas.~~
- ~~(b) Install the manufacturer approved GPS antenna in the location determined in paragraph A4.4.4(a), in accordance with the manufacturer's installation instructions, the aircraft maintenance manual and the guidelines in FAA AC43.13-1B. The GPS antenna installation should be tested to ensure that it will be restrained throughout the flight envelope.~~
- ~~(c) If using an internally mounted, manufacturer supplied remote antenna, install the antenna in accordance with the manufacturer's installation instructions. Ensure that the antenna and associated cable will not interfere with pilot's vision, aircraft controls or displays, or pilot/passenger egress.~~

A4.4.5 If the GPS is to be connected to the aircraft power supply, install and placard an appropriately rated circuit breaker or fuse.

A4.4.6 If required, install a remote GPS indicator as follows.

- (a) Determine a suitable location for the GPS indicator. The indicator should be located in the instrument panel and readily viewable to the pilot from his/her normally seated position.
- (b) Install the indicator in the location determined in **sub-section paragraph A4.4.6(a)**, in accordance with the manufacturer's installation instructions, the aircraft maintenance manual and the guidelines in FAA AC43.13-1B.

A4.4.7 Interconnect the GPS, power supply, indicator and antenna (as required) in accordance with the manufacturer's installation instructions. Aeronautical wire per FAA AC43.13-1B or equivalent is to be utilised.

A4.4.8 Replace the access panels removed in **sub-section paragraph A4.4.2** in accordance with the aircraft manufacturer's maintenance manual.

A4.4.9 For systems that may be used for navigation, install the following placard in the vicinity of the GPS and in clear view of the pilot:

GPS APPROVED FOR VFR USE ONLY

A4.4.10 Close the GPS circuit breaker or install the fuse.

A4.5 Post-Installation Testing

A4.5.1 Carry out a functional test of the GPS installation in accordance with the manufacturer's installation/operation instructions. Checks are also to be carried out to determine satisfactory operation of all disturbed systems, that there is no interference between avionics systems, no effect on the aircraft compass system and that there is no interference with the aircraft flight controls.

A4.5.2 For aircraft approved for night operations, ensure that the equipment lighting is satisfactory and that there are no unwanted reflections present.

A4.6 Manuals

A4.4.15 Generate and issue instructions for continued airworthiness (refer section 14.8).

A4.4.16 Insert the equipment operating instructions in the AFM/POH (refer section 14.9).

A4.7 Certification and release to service

A4.7.1 Amend the aircraft's weight and balance records (refer AC43-2).

A4.7.2 Complete or update ELA, retain copy with aircraft and submit copy with documentation (refer AC21-11 & 91-23).

A4.7.3 Amend the aircraft's form CAA 2129 if necessary (refer AC43-10).

A4.7.4 Complete form CAA043-01 *Modification Record*, and process as described in section paragraph 14 of this AC.

A4.7.5 Make a certified statement of release to service in accordance with rule 43.105, detailing the work carried out and conformity with Appendix 4 to this AC.

A5. APPENDIX 5—Installation of Audio Panel and Intercoms

A5.1 Description

A5.1.1 Installation of audio panel and intercom systems. This includes audio panels with marker beacon receivers.

A5.2 Applicability

A5.2.1 All limitations of sub-section paragraph 2.1 apply.

A5.2.1 Sections Paragraphs 1 to 14 of this AC apply.

A5.3 General

A5.3.1 Appendix 5 to this AC covers the procedures to be carried out when installing audio panel and intercom equipment.

A5.3.2 Consideration must be taken into account on whether the aircraft is to be operated under IFR or VFR and the approval level of the equipment to be installed (refer AC43-10).

- (a) For aircraft operating under IFR, the audio panel and intercom should be approved to level 1. A Level 2 or level 3 intercom may be used if the audio system can be configured to connect the pilot's microphone and headset directly to the level 1 audio panel or the VHF. This could be accomplished by the provision of emergency jacks.
- (b) For aircraft operating under VFR, the audio panel and intercom should be approved to level 1 or level 2. A level 3 intercom may be used if the audio system can be configured to connect the pilot's microphone and headset directly to the level 1 or level 2 audio panel or the VHF. This could be accomplished by the provision of emergency jacks.

A5.4 Technical instructions

A5.4.1 Ensure the aircraft is safe for servicing.

A5.4.2 Open the circuit breakers and/or remove the fuses for any equipment that is to be interfaced with the audio panel and/or intercom to be installed.

A5.4.3 Remove access panels etc. as required in accordance with the aircraft manufacturer's maintenance manual.

A5.4.4 Determine a suitable location(s) for the audio panel, intercom and headset/microphone jacks (as required) to be installed. Consideration should be given to:

- (a) accessibility and visibility of the equipment to the pilot
- (b) required operating environment for the equipment
- (c) required structural mounting provisions

- (d) no possibility of head-strike on the installed equipment for crew or passengers
- (e) no restriction during emergency egress.

A5.4.5 Install the equipment in accordance with the requirements and test loads in section 7 Equipment Installation.

~~A5.4.5 Install the equipment in the location(s) determined in paragraph A5.4.4. The installation is to be carried out in accordance with the manufacturer's installation instructions, the aircraft maintenance manual and the guidelines in FAA AC43.13-1B. The installation should be tested to ensure that it will be restrained throughout the flight envelope.~~

A5.4.6 If required, install an antenna in accordance with Appendix 15 of this AC.

A5.4.7 Interconnect the audio system, intercom and associated transmitters/receivers (as required) in accordance with the relevant manufacturer's installation instructions. Wire listed in FAA AC43.13-1B, Chapter 11 or equivalent is to be utilised.

A5.4.8 Install and placard a suitably rated circuit breaker or fuse.

A5.4.9 Replace the access panels removed in sub-section paragraph A5.4.3 in accordance with the aircraft manufacturer's maintenance manual.

A5.4.10 Close the audio panel/intercom circuit breaker or install the fuse.

A5.4.11 Close the circuit breakers and/or install the fuses opened/removed in sub-section paragraph A5.4.2.

A5.5 Post-Installation testing

A5.5.1 Post installation tests are to be carried out in accordance with the manufacturer's installation/operations manual to determine satisfactory operation of the installed equipment. Checks are also to be carried out to determine satisfactory operation of all disturbed systems, that there is no interference between avionics systems, no effect on the aircraft compass system and no interference with the aircraft flight controls. A check is also to be carried out to determine satisfactory fail-safe operation of the VHF in the event of an audio panel or intercom failure.

A5.5.2 For aircraft approved for night operations, ensure that the equipment lighting is satisfactory and that there are no unwanted reflections present.

A5.6 Manuals

A5.6.1 Generate and issue instructions for continued airworthiness (refer sub-section 14.8).

A5.6.2 Insert the equipment operating instructions in the AFM/POH (refer sub-section 14.9).

A5.7 Certification and release to service

- A5.7.1 Amend the aircraft's weight and balance records (refer AC43-2).
- A5.7.2 Complete or update ELA, retain copy with aircraft and submit copy with documentation (refer AC21-11 & 91-23).
- A5.7.3 Amend the aircraft's form CAA 2129, if necessary (refer AC43-10).
- ~~A5.4.14 Generate and issue instructions for continued airworthiness (refer paragraph 14.8).~~
- ~~A5.4.15 Insert the equipment operating instructions in the AFM/POH (refer paragraph 14.9).~~
- A5.7.5 Complete form CAA043-01 *Modification Record* and process as described in **section** ~~paragraph~~ 14 of this AC.
- A5.7.6 Make a certified statement of release to service in accordance with rule 43.105, detailing the work carried out and conformity with Appendix 5 of this AC.

A6. APPENDIX 6—Installation of VHF Radio Communications

A6.1 Description

A6.1.1 Installation of an aeronautical VHF transceiver. This includes VHF communications equipment with integral VHF radio navigation receivers (refer A6.8).

A6.2 Applicability

A6.2.1 All limitations of sub-section paragraph 2.1 apply.

A6.2.2 Sections Paragraphs 1 to 14 of this AC apply.

A6.3 General

A6.3.1 This appendix provides installation instructions for aeronautical VHF transceivers. The transceivers must meet the appropriate approval level for the intended type of operation as required by Part 91, Appendix A9(a).

A6.3.2 For IFR operations the VHF must be approved to level 1 and for VFR operations approved to either level 1 or level 2. Approval levels for commonly used equipment are detailed in AC43-10.

A6.4 Technical instructions

A6.4.1 Ensure the aircraft is safe for servicing.

A6.4.2 Remove access panels etc. as required in accordance with the aircraft manufacturer's maintenance manual.

A6.4.3 Install the VHF as follows.

- (a) Determine a suitable location for the VHF. The VHF should be located in a position that is viewable and accessible to the pilot from his/her normally seated position. The installed VHF should not:
 - (1) restrict access to or view of any control, display or indicator
 - (2) restrict movement of the flight controls
 - (3) interfere with the pilot's vision along the flight path, or
 - (4) restrict pilot/passenger egress.
- ~~(b)~~ Install the VHF at the location determined in sub-section paragraph A6.4.3(a) in accordance with the requirements and test loads in section 7 Equipment Installation. ~~The installation is to be carried out in accordance with the manufacturer's installation instructions, the aircraft maintenance manual and the guidelines in FAA AC43.13-1B. The installation should conform to the following requirements.~~
 - ~~(1) Manufacturer supplied or standard parts should be used.~~
 - ~~(2) The VHF mounting should be tested to ensure that the VHF and rack will be restrained throughout the flight envelope.~~

- ~~(3) Where a modification is required to the aircraft structure to show compliance with paragraph A6.4.3(b)(2), the modification is to be carried out in accordance with the aircraft maintenance manual and the guidelines in FAA AC43.13-1B.~~

A6.4.4 If required, install an antenna in accordance with Appendix 15 of this AC.

~~(c) If required, install an antenna as follows.~~

- ~~(1) Determine a suitable location for the VHF antenna. Antennas should be installed in accordance with FAA AC43-13.2B, chapter 3 or aircraft manufacturer approved locations. The antenna is not to be installed within 0.9m of any other antenna. If an antenna is to be installed in other than an approved location, post installation ground and flight tests are to be carried out to confirm the suitability of the antenna location.~~
- ~~(2) Install the manufacturer approved VHF antenna in the location determined in paragraph A6.4.3(c)(1), in accordance with the manufacturer's installation instructions, the aircraft maintenance manual and the guidelines in FAA AC43.13-2B. The VHF antenna installation should be tested to ensure that it will be restrained throughout the flight envelope.~~

A6.4.5 Install and placard an appropriately rated circuit breaker or fuse.

A6.4.6 Interconnect the VHF, power supply, audio panel and intercom (as required) in accordance with the manufacturer's installation instructions. Wire listed in **FAA** AC43.13-1B, Chapter 11 or equivalent is to be utilised.

A6.4.7 Replace the access panels removed in **sub-section** paragraph A6.4.2 in accordance with the aircraft manufacturer's maintenance manual.

A6.4.8 Close the VHF circuit breaker or install the fuse.

A6.5 Post-Installation testing

A6.5.1 Carry out a functional test of the VHF installation in accordance with the manufacturer's installation/operation instructions and Part 43, Appendix B. Checks are also to be carried out to determine satisfactory operation of all disturbed systems, that there is no interference between avionics systems, no effect on the aircraft compass system and that there is no interference with the aircraft flight controls.

A6.5.2 For aircraft approved for night operations, ensure that the equipment lighting is satisfactory and that there are no unwanted reflections present.

A6.6 Manuals

A6.6.1 Generate and issue instructions for continued airworthiness (refer sub-section 14.8).

A6.6.2 Insert the equipment operating instructions in the AFM/POH (refer sub-section 14.9).

A6.7 Certification and release to service

A6.7.1 Amend the aircraft's weight and balance records (refer AC43-2).

A6.7.2 Complete or update ELA, retain copy with aircraft and submit copy with documentation (refer AC21-11 & 91-23).

A6.7.3 Amend the aircraft's form CAA 2129, if necessary (refer AC43-10).

A6.7.4 Complete form CAA043-01 *Modification Record* and process as described in section paragraph 14 of this AC.

A6.7.5 Make a certified statement of release to service in accordance with rule 43.105, detailing the work carried out and conformity with Appendix 6 of this AC.

A6.8 Installation of Nav/Com Units

A6.8.1 The installation of dual functionality (combined) VHF radio navigation receiver and VHF communication transceiver (Nav/Com) equipment may be accomplished using this Appendix providing the additional steps described below are complied with.

A6.8.2 The Nav/Com equipment must meet the requirements of this appendix and Appendix A7, sub-section A7.3.

A6.8.3 The navigation indicator to be interfaced with must be an approved model number in the Nav/Com installation manual.

A6.8.4 The installation of the VHF navigation antenna, if needed, must meet the requirements in Appendix 15.

A7. APPENDIX 7—Installation of VHF Radio Navigation Receivers and Distance Measuring Equipment

A7.1 Description

A7.1.1 Installation of an aeronautical VHF navigation receiver, indicator and distance measuring equipment (DME).

A7.2 Applicability

A7.2.1 All limitations of **sub-section paragraph** 2.1 apply.

A7.2.2 **Sections Paragraphs** 1 to 14 of this AC apply.

A7.3 General

A7.3.1 This appendix provides installation instructions for aeronautical VHF navigation receivers, an associated indicator and DME systems. The receiver, indicator and DME must meet the appropriate approval level for the intended type of operation as required by Part 91, Appendix A9(a).

A7.3.2 For IFR operations the equipment must be approved to level 1. Approval levels for commonly used equipment are detailed in AC43-10.

A7.4 Technical instructions

A7.4.1 Ensure the aircraft is safe for servicing.

A7.4.2 Remove access panels etc. as required in accordance with the aircraft manufacturer's maintenance manual.

A7.4.3 Install the navigation receiver or DME as follows:

(a) Determine suitable locations for the receiver, DME and indicator. The receiver and DME should be located in a position which is viewable and accessible to the pilot from his/her normally seated position. If required for approach navigation, the indicator should be located in the pilot's primary field-of-view so that the indicator is viewable by the pilot when looking along the aircraft's flight path. The installed receiver, DME and indicator should not:

- (1) restrict access to or view of any control, display or indicator
- (2) restrict movement of the flight controls
- (3) interfere with the pilot's vision along the flight path, or
- (4) restrict pilot/passenger egress.

(b) Install the receiver, DME and indicator at the locations determined in **sub-section paragraph** A7.4.3(a). The installations are to be carried out in accordance with the manufacturer's installation instructions, the aircraft maintenance manual and the guidelines in FAA AC43.13-1B. The installations should conform to the following requirements:

- (1) Manufacturer-supplied or standard parts should be used.
- (2) The equipment mounting should be tested to ensure that the receiver, indicator and associated rack(s) would be restrained throughout the flight envelope.
- (3) Where a modification is required to the aircraft structure to show compliance with **sub-section paragraph A7.4.3(b)(2)**, the modification is to be carried out in accordance with the aircraft maintenance manual and the guidelines in FAA AC43.13-1B.

A7.4.4 If required, install an antenna **in accordance with Appendix A15**.

~~If required, install an antenna as follows.~~

- ~~(a) Determine a suitable location for the antenna. Antennas should be installed in accordance with FAA AC43.13-2B Chapter 3, or aircraft manufacturer approved locations. The antenna is not to be installed within 0.9m of any other antenna. If an antenna is to be installed in other than an approved location, post installation ground and flight tests are to be carried out to determine the suitability of the antenna location.~~
- ~~(b) Install the manufacturer approved antenna in the location determined in paragraph A7.4.4(a) in accordance with the manufacturer's installation instructions, the aircraft maintenance manual and the guidelines in FAA AC43.13-2B, Chapter 3. The antenna installation should be tested to ensure that it will be restrained throughout the flight envelope.~~

A7.4.5 Install and placard an appropriately rated circuit breaker or fuse.

A7.4.6 Interconnect the navigation receiver, DME, power supply, navigation indicator and audio panel (as required) in accordance with the manufacturer's installation instructions. Wire listed in FAA AC43.13-1B, Chapter 11 or equivalent is to be utilised.

A7.4.7 Replace the access panels removed in **sub-section paragraph A7.4.2** in accordance with the aircraft manufacturer's maintenance manual.

A7.4.8 Close the receiver circuit breaker or install the fuse.

A7.5 Post-Installation testing

A7.5.1 Carry out a functional test of the navigation receiver installation in accordance with the manufacturer's installation/operation instructions and Part 43, Appendix B. Checks are also to be carried out to determine satisfactory operation of all disturbed systems, that there is no interference between avionics systems, no effect on the aircraft compass system and that there is no interference with the aircraft flight controls.

A7.5.2 For aircraft approved for night operations, ensure that the equipment lighting is satisfactory and that there are no unwanted reflections present.

A7.6 Manuals

A7.6.1 Generate and issue instructions for continued airworthiness (refer sub-section 14.8).

A7.6.2 Insert the equipment operating instructions in the AFM/POH (refer sub-section 14.9).

A7.7 Certification and release to service

A7.7.1 Amend the aircraft's weight and balance records (refer AC43-2).

A7.7.2 Complete or update ELA, retain copy with aircraft and submit copy with documentation (refer AC21-11 & 91-23).

A7.7.3 Amend the aircraft's form CAA 2129, if necessary (refer AC43-10).

A7.7.4 Complete form CAA043-01 *Modification Record* and process as described in section paragraph 14 of this AC.

A7.7.5 Make a certified statement of release to service in accordance with rule 43.105, detailing the work carried out and conformity with Appendix 7 of this AC.

A8. APPENDIX 8—Installation of Voltage Converters

A8.1 Description

A8.1.1 Installation of voltage converters.

A8.2 Applicability

A8.2.1 All limitations of **sub-section paragraph** 2.1 apply.

A8.2.2 **Sections Paragraphs** 1 to 14 of this AC apply.

A8.3 General

A8.3.1 Appendix 8 of this AC covers the procedures to be carried out when installing voltage converters.

A8.3.2 The procedure is only applicable for installations which can be installed on a 'no hazard, no interference' basis. If comprehensive testing or analysis is required, the modification documentation is to be submitted for approval, using a form CAA337, to either the CAA or a certificated Part 146 design organisation.

A8.3.3 When using this procedure, the following points should be observed:

- (a) The equipment is to be suitable for use in aircraft. Examples of items to be considered are:
 - (1) the operating environment
 - (2) structural integrity of the equipment throughout the flight envelope, **and**
 - (3) flammability requirements.
- (b) The equipment should be suitable for the intended purpose. The equipment must be compatible with other systems on the aircraft. If the equipment interfaces with other systems, for example: power supplies, audio panel, intercom units etc., it must not affect the operation of the other systems.
- (c) The equipment must not present a hazard either by its:
 - (1) construction
 - (2) installation
 - (3) interface, or
 - (4) operation.
- (d) If being used to provide power for required IFR equipment (e.g. VHF communication or navigation equipment) then the voltage converter must be level 1 approved.

A8.4 Technical instructions

A8.4.1 Ensure the aircraft is safe for servicing.

A8.4.2 Remove access panels etc. as required in accordance with the aircraft manufacturer's maintenance manual.

A8.4.3 Determine a suitable location for the voltage converter. Consideration should be given to:

- (a) required operating environment for the equipment
- (b) any cooling requirements for the voltage converter
- (c) required structural mounting provisions.

A8.4.4 Install the equipment in the location determined in **sub-section paragraph** A8.4.3. The installation is to be carried out in accordance with the manufacturer's installation instructions, the aircraft maintenance manual and the guidelines in FAA AC43.13-1B. The installation should be tested to ensure that it will be restrained throughout the flight envelope.

A8.4.5 Electrically connect the voltage converter in accordance with the manufacturer's installation instructions and the aircraft maintenance manual. The voltage converter is to be powered via an appropriately rated, placarded circuit protective device. Wire listed in FAA AC43.13-1B, Chapter 11 or equivalent is to be utilised.

A8.4.6 Replace any access panels removed in **sub-section paragraph** A8.4.2.

A8.5 Post-Installation Testing

A8.5.1 Post installation tests are to be carried out to determine satisfactory operation of the installed equipment. Checks are also to be carried out to determine satisfactory operation of all disturbed systems, that there is no interference between avionics systems, no effect on the aircraft compass system and no interference with the aircraft flight controls.

A8.6 Manuals

A8.6.1 Generate and issue instructions for continued airworthiness (refer sub-section 14.8).

A8.6.2 Insert the equipment operating instructions in the AFM/POH (refer sub-section 14.9).

A8.7 Certification and release to service

A8.7.1 Amend the aircraft's weight and balance records (refer AC43-2).

A8.7.2 Complete or update ELA, retain copy with aircraft and submit copy with documentation (refer AC21-11 & 91-23).

A8.7.3 Amend the aircraft's form CAA 2129, if necessary (refer AC43-10).

A8.7.4 Complete form CAA043-01 *Modification Record* and process as described in **section paragraph** 14 of this AC.

A8.7.5 Make a certified statement of release to service in accordance with rule 43.105, detailing the work carried out and conformity with Appendix 8 of this AC.

A9. APPENDIX 9—Installation of ‘Non-Aeronautical’ Electronics Equipment

A9.1 Description

A9.1.1 Installation of ‘non-aeronautical’ electronics equipment.

A9.2 Applicability

A9.2.1 All limitations of **sub-section paragraph 2.1** apply.

A9.2.2 **Sections Paragraphs 1 to 14** of this AC apply.

A9.3 General

A9.3.1 Appendix 9 of this AC covers the procedures to be carried out when installing ‘non-aeronautical’ electronics equipment. Examples of non-aeronautical electronics equipment covered by this Appendix are:

- (a) cellular telephones
- (b) audio entertainment systems
- (c) FM transceivers
- (d) Stand-alone flight monitoring/tracking devices (excluding those with in-aircraft display systems).**

A9.3.2 The procedure is only applicable for installations which can be installed on a ‘no hazard, no interference’ basis. If extensive testing or analysis is required, the modification documentation is to be submitted for approval, using a form CAA337, to either CAA or a certificated Part 146 design organisation.

A9.3.3 When using this procedure, the following points should be observed.

- (a) The equipment is to be suitable for use in aircraft. Examples of aspects to be considered when determining this are:
 - (1) the operating environment
 - (2) structural integrity of the equipment throughout the flight envelope
 - (3) ability of the antenna installation to withstand aerodynamic loads
 - (4) flammability requirements.
- (b) The equipment should be suitable for the intended purpose. The equipment must have the required functionality and be suitable for operation in aircraft by crew or passengers as applicable. The equipment must also be compatible with other systems on the aircraft. If the equipment interfaces with other systems, for example: power supplies, audio panel, intercom units etc., it must not affect the operation of the other systems.
- (c) The equipment must not present a hazard either by its:

- (1) construction
 - (2) installation
 - (3) interface,
 - (4) operation.
- (d) Installed cellular telephones are to be:
- (1) approved for connection to any New Zealand cellular network only, and
 - (2) disabled during approach and take-off when operating under IFR.
- (e) The installed equipment should be compatible. For example:
- (1) an antenna being utilised must be suitable for the intended purpose and matched to the transceiver with which it is being used, and
 - (2) if installing a radio, it must be compatible with the aircraft audio system.

A9.4 Technical instructions

A9.4.1 Ensure the aircraft is safe for servicing.

A9.4.2 Remove access panels etc. as required in accordance with the aircraft manufacturer's maintenance manual.

A9.4.3 Determine a suitable location(s) for all equipment to be installed. Consideration should be given to:

- (a) accessibility and visibility of the equipment to the pilot
- (b) required operating environment for the equipment
- (c) required structural mounting provisions
- (d) no possibility of head-strike on the installed equipment for crew or passengers, and
- (e) no restriction during emergency egress.

A9.4.4 Install the equipment in the location(s) determined in sub-section paragraph A9.4.3. The installation is to be carried out in accordance with the manufacturer's installation instructions, the aircraft maintenance manual and the guidelines in FAA AC43.13-1B. The installation should be tested to ensure that it will be restrained throughout the flight envelope.

A9.4.5 Electrically connect the equipment in accordance with the manufacturer's installation instructions and the aircraft maintenance manual. The equipment is to be powered via an appropriately rated, placarded circuit protective device. Wire listed in FAA AC43.13-1B Chapter 11 or equivalent is to be utilised.

A9.4.6 Antennas should be installed in accordance with Appendix 15 of this AC.

~~Antennas should be installed in accordance with FAA AC43.13-2B Chapter 3 or aircraft manufacturer approved locations. If an antenna is to be installed in other than an approved location:~~

- ~~(a) the antenna is not to be installed within 0.9m of another antenna~~
- ~~(b) post installation ground and flight tests are to be carried out to confirm the suitability of the antenna location.~~

A9.4.7 Replace any access panels removed in **sub-section** ~~paragraph~~ A9.4.2.

A9.5 Post-Installation Testing

A9.5.1 Post installation ground and, if required, flight tests are to be carried out to determine satisfactory operation of the installed equipment. Checks are also to be carried out to determine satisfactory operation of all disturbed systems, that there is no interference between avionics systems, no effect on the aircraft compass system and no interference with the aircraft flight controls.

A7.5.2 For aircraft approved for night operations, ensure that the equipment lighting is satisfactory and that there are no unwanted reflections present.

A9.6 Manuals

A9.6.1 Generate and issue instructions for continued airworthiness (refer sub-section 14.8).

A9.6.2 Insert the equipment operating instructions in the AFM/POH (refer sub-section 14.9).

A9.7 Certification and release to service

A9.7.1 Amend the aircraft's weight and balance records (refer AC43-2).

A9.7.2 Complete or update ELA, retain copy with aircraft and submit copy with documentation (refer AC21-11 & 91-23).

A9.7.3 Amend the aircraft's form CAA 2129, if necessary (refer AC43-10).

A9.7.4 Complete form CAA043-01 *Modification Record* and process as described in **section** ~~paragraph~~ 14 of this AC.

A9.7.5 Make a certified statement of release to service in accordance with rule 43.105, detailing the work carried out and conformity with Appendix 9 of this AC.

A10. APPENDIX 10—Installation of 12VDC Electrical Distribution System for Gliders

A10.1 Description

A10.1.1 Installation of a 12VDC electrical distribution system in gliders where no electrical system has been provided by the manufacturer.

A10.2 Applicability

A10.2.1 All gliders without a 12VDC electrical system installed by the glider's manufacturer where the modification is not classified as a major modification.

A10.2.2 **Sections** Paragraphs 1 to 14 of this AC apply.

A10.3 General

A10.3.1 Appendix 10 of this AC provides installation instructions for a 12VDC electrical distribution system in a glider and does not provide for the installation of a battery. This appendix assumes that the installed battery is, or batteries are, appropriately rated for the maximum electrical load of the distribution system.

A10.3.2 If required, the installation of a battery should be carried out in accordance with a modification approved by either:

- (a) the glider manufacturer
- (b) CAA, or
- (c) a certificated Part 146 design organisation.

A10.3.3 This modification will result in the installation of the following electrical system components:

A10.3.4 A **master switch** located on the instrument panel. When in the OFF position, the switch must electrically isolate the battery from all other components and instruments. The switch should be of aeronautical quality and appropriately rated for the maximum electrical load.

A10.3.5 A **master circuit breaker**. An electrical load analysis of the instruments and equipment to be powered from the distribution system should be carried out to determine the maximum load. The master circuit breaker should be rated to 1.5 times the maximum load.

A10.3.6 **In-line fusing** of both the positive and negative wires, located as close as practical to the battery. The fuse in the positive line of each battery should be double the value of the circuit breaker, and the fuse in the negative line of each battery should be double the value of the fuse in the positive line. This fusing is compliant with DCA/ELECT/8 requirements for composite and wooden airframes.

A10.3.7 A **terminal block** to terminate the supply and allow multiple distribution to the equipment requiring power. The terminal block should be suitable for use in aeronautical applications.

A10.3.8 **Aeronautical mil spec wire.** Two mil spec wires from a single battery, and three mil spec wires from dual battery sources are to be installed. Wires are to be sized by using the intermittent rating chart in FAA AC43.13-1B, Chapter 11.

A10.4 Technical instructions

A10.4.1 Ensure the glider is safe for servicing.

A10.4.2 Remove access panels as required in accordance with the glider manufacturer's maintenance manual to afford access for the running of wires and the installation of electrical components.

A10.4.3 Determine suitable locations for the master switch, circuit breaker and terminal block.

- (a) The master switch is to be located in the instrument panel in a position which is readily accessible and viewable to the pilot.
- (b) The master circuit breaker is to be located in a position that is viewable and accessible to the pilot from his or her normally seated position.
- (c) The terminal block is to be located in a position forward of the instrument panel where the terminals will not contact the pilot or any structure, components or controls.

A10.4.4 Install the master switch, circuit breaker and terminal block in the positions determined in **sub-section paragraph** A10.4.3 in accordance with the relevant manufacturer's instructions and the guidelines in FAA AC43.13-1B.

A10.4.5 Route and connect wiring in accordance with Figure 1.

- (a) Wire listed in FAA AC43.13-1B Chapter 11 as specified in **sub-section paragraph** A10.3.13 is to be utilised.
- (b) Connect the supply lines from the battery via a polarised connector to ensure that the battery, or batteries, cannot be connected in such a way as to apply reverse polarity to the distribution system.
- (c) The master circuit breaker and battery fuses should be rated as determined in **sub-sections paragraphs** A10.3.10 and A10.3.11.
- (d) Cable routing is to be in accordance with FAA AC43.13-1B, Chapter 11.

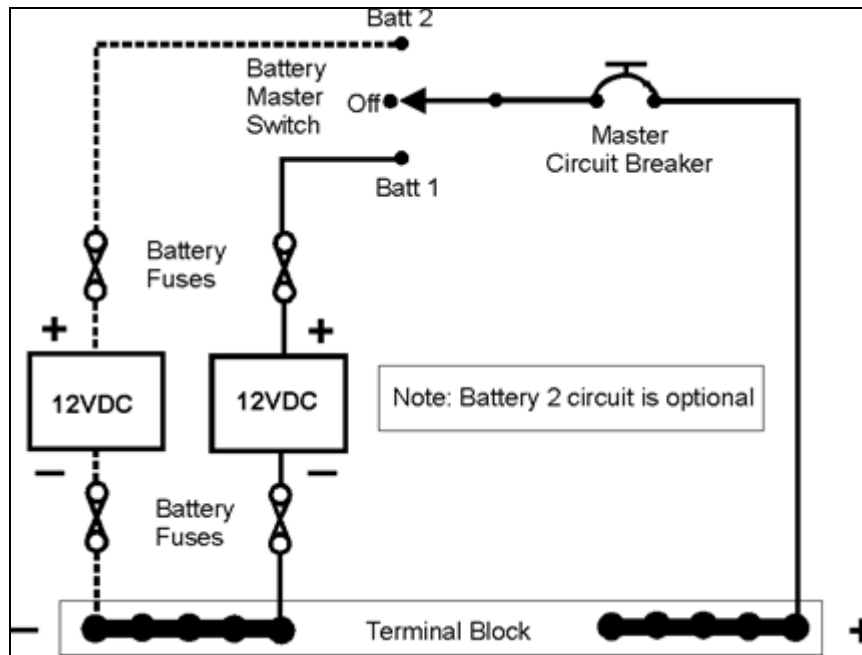

Figure 1

A10.4.6 Placard the master switch, master circuit breaker, battery fuses and terminal block.

A10.4.7 Replace any access panels removed in **sub-section paragraph** A10.4.2.

A10.5 Post-Installation Testing

A10.5.1 Post installation ground tests are to be carried out to determine satisfactory operation of the electrical distribution system. Checks are to be carried out to determine the correct polarity voltage of the distribution system and satisfactory operation of the master switch. Checks are also to be carried out to determine satisfactory operation of all disturbed systems, that there is no interference between avionics systems, no effect on the glider compass and no interference with the flight controls.

A10.6 Manuals

A10.6.1 Generate and issue instructions for continued airworthiness (refer **sub-section 14.8**).

A10.6.2 A circuit diagram of the electrical system should be inserted into the maintenance subsection of the flight manual, with the note that the system is to be maintained in accordance with the current approved maintenance program for the glider (refer **sub-section 14.9**).

A10.7 Certification and release to service

A10.7.1 Amend the aircraft's weight and balance records (refer AC43-2).

A10.7.2 Complete or update ELA, retain copy with aircraft and submit copy with documentation (refer AC21-11 & 91-23).

~~A10.4.11 — Generate and issue instructions for continued airworthiness (refer paragraph 14.8).~~

~~A10.4.12 — A circuit diagram of the electrical system should be inserted into the maintenance subsection of the flight manual, with the note that the system is to be maintained in accordance with the current approved maintenance program for the glider (refer paragraph 14.9).~~

A10.7.3 Complete form CAA043-01 *Modification Record* and process as described in section paragraph 14 of this AC.

A10.7.4 Make a certified statement of release to service in accordance with rule 43.105, detailing the work carried out and conformity with Appendix 10 of this AC.

A11. APPENDIX 11—Removal of Avionics Systems

A11.1 Description

A11.1.1 Removal of avionics systems.

A11.2 Applicability

A11.2.1 All limitations of **sub-section paragraph** 2.1 apply.

A11.2.2 **Sections Paragraphs** 1 to 14 of this AC apply.

A11.3 General

A11.3.1 Appendix 11 of this AC covers the procedures to be carried out when removing avionics equipment.

A11.4 Technical instructions

A11.4.1 Ensure the aircraft is safe for servicing.

A11.4.2 Remove access panels etc. as required in accordance with the aircraft manufacturer's maintenance manual.

A11.4.3 Open the circuit breaker(s) or remove the fuse(s) for the system to be removed.

A11.4.4 Remove the equipment and associated racks, wiring, switches, indicators, ~~antennas~~, circuit breakers, fuses and antennas as required.

A11.4.5 Any retained indicators or switches should be placarded 'inoperative' as applicable.

A11.4.6 Any retained wiring looms should be bagged, stowed and secured as applicable.

A11.4.7 Any holes (equipment, instrument, switch, antenna mounting holes etc.) are to be blanked as applicable. The holes are to be blanked in accordance with aircraft maintenance manual and the guidelines in FAA AC43.13-1B.

A11.4.8 Replace any access panels removed in **sub-section paragraph** A11.4.2.

A11.5 Post-Installation Testing

A11.5.1 Checks are to be carried out to determine satisfactory operation of all disturbed systems, that there is no interference between avionics systems, no degradation of earthing or bonding, no effect on the aircraft compass system and no interference with the aircraft flight controls.

A11.6 Manuals

A11.6.1 **Generate and issue/remove/amend instructions for continued airworthiness (refer sub-section 14.8).**

A11.6.2 Remove/amend the equipment operating instructions in the AFM/POH (refer sub-section 14.9).

A11.6.3 Amend the aircraft's weight and balance records (refer AC43-2).

A11.6.4 Complete or update ELA, retain copy with aircraft and submit copy with documentation (refer AC21-11 & 91-23).

A11.6.5 Amend the aircraft's form CAA 2129, if necessary (refer AC43-10).

~~A11.4.13 Generate and issue/remove/amend instructions for continued airworthiness (refer paragraph 14.8).~~

~~A11.4.14 Remove/amend the equipment operating instructions in the AFM/POH (refer paragraph 14.9).~~

A11.6.6 Complete form CAA043-01 *Modification Record* and process as described in section paragraph 14 of this AC.

A11.6.7 Make a certified statement of release to service in accordance with rule 43.105, detailing the work carried out and conformity with this Appendix 11 of this AC.

A12. APPENDIX 12—Installation of Situation Awareness Equipment for Gliders

A12.1 Description

A12.1.1 Installation of situation awareness equipment e.g. FLARM into gliders.

A12.2 Applicability

A12.2.1 All gliders with a 12VDC electrical system installed where the modification is not classified as a major modification.

A.12.2.2 **Sections** Paragraphs 1 to 14 of this AC apply.

A12.3 General

A12.3.1 Appendix 12 of this AC provides for the installation of situation awareness equipment into gliders and connection to the glider 12 VDC electrical distribution system.

A12.3.2 The FLARM equipment should be installed in accordance with:

- (a) the equipment manufacturer's installation manual.
- (b) FAA AC43-13-1B standard practices.

A12.3.3 If the FLARM equipment requires the use of the external GPS antenna, this should be installed in accordance with Appendix **15 (4)** of this AC. ~~and the manufacturer's instructions.~~

A12.4 Technical instructions

A12.4.1 Ensure the glider is safe for servicing.

A12.4.2 Remove access panels etc. as required in accordance with the glider manufacturer's maintenance manual.

A12.4.3 Determine a suitable location for all equipment to be installed. Consideration should be given:

- (a) to accessibility and visibility of the equipment to the pilot
- (b) to required operating environment for the equipment
- (c) to required structural mounting provisions
- (d) **to ensuring** that no possibility of head-strike exists on the installed equipment for crew or passengers
- (e) **to ensuring** no restriction during emergency egress
- (f) **to ensuring it** does not obscure any other essential instrument displays.

A12.4.4 Install the equipment in the location(s) determined in **sub-section paragraph A12.4.3**. The installation is to be carried out in accordance with the manufacturer's installation instructions, the glider maintenance manual and the guidelines in FAA AC43.13-1B. Use manufacturer supplied parts when provided. The installation should be tested to ensure that it will be restrained throughout the flight envelope.

A12.4.5 Electrically connect the equipment in accordance with the manufacturer's installation instructions and the aircraft maintenance manual. The equipment is to be powered via an independent, appropriately rated, and placarded circuit protective device. Suitable aeronautical wire listed in FAA AC43.13-1B, Chapter 11 or equivalent is to be utilised.

A12.4.6 Replace any access panels removed in **sub-section paragraph A12.4.2**.

A12.5 Post-Installation Testing

A12.5 Test the system in accordance with the manufacturer's instructions. Verify that:

- (a) the software loaded into the system is the current version
- (b) the FLARM does not cause interference to other installed equipment
- (c) equipment installed in the glider do not cause interference with the situation awareness equipment.

A12.6 Manuals

A12.6.1 Generate and issue instructions for continued airworthiness (refer **sub-section 14.8**).

A12.6.2 Insert the equipment operating instructions in the AFM/POH (refer **sub-section 14.9**).

A12.7 Certification and release to service

A12.7.1 Amend the aircraft's weight and balance records (refer AC43-2).

A12.7.2 Complete or update ELA, retain copy with aircraft and submit copy with documentation (refer AC21-11 & 91-23).

A12.7.3 Amend the aircraft's form CAA 2129, if necessary (refer AC43-10).

~~A12.4.11 Generate and issue instructions for continued airworthiness (refer paragraph 14.8).~~

~~A12.4.12 Insert the equipment operating instructions in the AFM/POH (refer paragraph 14.9).~~

A12.7.4 Complete form CAA043-01 *Modification Record* and process as described in **section paragraph 14** of this AC.

A12.7.5 Make a certified statement of release to service in accordance with rule 43.105, detailing the work carried out and conformity with Appendix 12 of this AC.

A13. APPENDIX 13—Installation of Stand-alone ADS-B Systems

A13.1 Description

A13.1.1 Installation of an FAA TSO-C166b transponder, with integral or dedicated external (“blind”) GNSS position source meeting FAA TSO-C145(); and a TSO-C88() altitude encoder.

A13.2 Applicability

A13.2.1 ADS-B systems to be installed under this AC are:

- (a) covered by an approved model list-supplemental type certificate (AML-STC), where the aircraft model is not included in the AML or eligibility list of the STC.
- (b) those where the AML-STC is for an aircraft of similar construction and type (e.g. normal category fixed-wing all-metal aircraft, or small composite rotorcraft) (refer to sub-section paragraph A13.3.4 (a) through (c) for examples of how this applies).

A13.2.2 The intent of this appendix is to address installation of systems to aircraft not on the approval model list.

A13.2.3 Sections Paragraphs 1 to 14 of this AC apply.

A13.3 Limitations

A13.3.1 This AC does not apply to ADS-B systems that interface with or include a traffic advisory or traffic avoidance systems (e.g. TAS, TCAD, TCAS)

Note: ADS-B IN is considered part of the ADS-B system when it is an integrated part of the stand-alone system.

A13.3.2 All limitations of sub-section paragraph 2.1 apply.

A13.3.3 This AC only applies to stand-alone ADS-B systems, i.e. equipment that includes both a Mode S transponder with extended squitter, and a GNSS position source within a single physical unit, or an external (“blind”) GNSS position source approved by the transponder OEM and dedicated to the ADS-B system. The GNSS source may not interface to other systems.

A13.3.4 This AC only applies to those systems approved by an AML-STC, where the aircraft model is not included by the AML, where the STC is applicable to an aircraft of similar construction and type that would otherwise be considered acceptable to the Director. This is to ensure that the equipment installation data is appropriate and the equipment is qualified for the environmental (e.g. vibration, HIRF, EMI/EMC) conditions to be expected during normal operation. For example:

- (a) If the STC is approved on FAR 23 certified aircraft – the equipment may be installed on other similar fixed-wing aircraft of the same general construction, under this appendix, provided all other requirements are met.

- (b) If the STC is approved on FAR 27 certified rotorcraft – the equipment may be installed on other similar small rotorcraft of the same general construction, under this appendix, provided all other requirements are met.
- (c) If the STC is approved on FAR 29 certified rotorcraft – the equipment may be installed on other similar rotorcraft of the same general construction, under this appendix, provided all other requirements are met.
- (d) Equipment only approved on a fixed-wing aircraft cannot be installed on a rotorcraft, and vice versa.
- (e) Installation data must be applicable and appropriate for the aircraft's general construction (e.g. all-metal, glass-reinforced plastic or wood).

A13.3.5 ADS-B systems that acquire a GNSS position source from a unit or system that also supplies GNSS position source data to other systems (e.g. to flight management systems or navigation systems) may create new failure conditions and classifications that require analysis by a certificated Part 146 design organisation, and are **not** captured by this AC.

A13.3.6 Existing antennas and altitude encoders may be used provided they are compatible with the ADS-B system and included in the equipment manufacturer's documentation.

A13.3.7 Any limitations defined by the equipment manufacturer apply.

A13.3.8 The installer should have the written permission of the STC holder to use the technical data.

A13.4 General

A13.4.1 A system ground test verifying all transmitted data according to Notice of Requirements NTC 91.258 has to be performed.

A13.4.2 Notice of Requirements NTC 91.258, requires that transponders meet the requirements of TSO-C166b (or equivalent). **This AC only applies to transponders meeting FAA TSO-C166b.**

A13.4.3 Notice of Requirements NTC 91.258, requires that GNSS position sources meet the requirements of TSO-C145(), TSO-C146() or TSO-C196 (or equivalent). **Only GNSS position sources meeting FAA TSO-C145() are covered in this AC.**

A13.4.4 Part 91, Appendix A.23, requires that each altitude encoder meets the requirements of TSO-C88().

A13.5 Technical instructions

A13.5.1 Ensure the aircraft is safe for servicing.

A13.5.2 Remove access panels etc. as required in accordance with the aircraft manufacturer's maintenance manual.

A13.5.3 If an existing transponder is to be removed.

- (a) Open the transponder circuit breaker or remove the transponder fuse, as required, to isolate power from the existing transponder.
- (b) Remove the existing transponder, mounting tray, antenna and wiring as required.

A13.5.4 Install the ADS-B system in accordance with the STC installation technical data.

A13.5.5 Install the transponder as follows:

- (a) If the transponder is being installed in a new location, determine a suitable location for the transponder. The transponder should be located in a position which is viewable and accessible to the pilot from his/her normally seated position. The preferred location is a standard manufacturer-installed avionics rack.
- (b) Install the transponder mounting tray at the location determined in **sub-section paragraph A13.5.5(a)**. The installation is to be carried out in accordance with the manufacturer's installation instructions, the aircraft maintenance manual and the guidelines in FAA AC43.13-1B. The installation should also conform to the following requirements:
 - (1) Manufacturer-supplied or standard parts should be used.
 - (2) The transponder mounting should be tested to ensure that the transponder and rack will be restrained throughout the flight envelope.
 - (3) Where a modification is required to the aircraft structure to show compliance with **sub-section paragraph A13.5.5(b)(2)**, the modification is to be carried out in accordance with the aircraft maintenance manual and the guidelines in FAA AC43.13-1B.

A13.5.6 If required, install the transponder antenna **in accordance with Appendix 15 of this AC.**

~~If required, install the transponder antenna as follows.~~

- ~~(a) Determine an approved location for the transponder antenna in accordance with FAA AC43.13-2B or the aircraft manufacturer's instructions. The antenna should not be located within 0.9m of any other antenna.~~
- ~~(b) Install the transponder antenna in the location determined in paragraph A13.5.6(a), in accordance with the manufacturer's installation instructions, the aircraft maintenance manual and the guidelines in FAA AC43.13-1B. The transponder antenna installation should be tested to ensure that it will be restrained throughout the flight envelope.~~

A13.5.7 If required, install the remote GNSS antenna **in accordance with Appendix 15 of this AC.**

If required, install the remote GNSS antenna as follows.

- ~~(a) Determine an approved location for the GNSS antenna on the upper fuselage in accordance with FAA AC43.13-2B or the aircraft manufacturer's instructions. The antenna should not be located within 1.1m of any other antenna. Particular care should be taken to ensure that at least the minimum separation is maintained between the GNSS antenna and VHF communications and ELT antennas.~~
- ~~(b) Install the manufacturer approved GNSS antenna in the location determined in paragraph A13.5.7(a), in accordance with the manufacturer's installation instructions, the aircraft maintenance manual and the guidelines in FAA AC43.13-1B. The GNSS antenna installation should be tested to ensure that it will be restrained throughout the flight envelope.~~
- ~~(c) If using an internally mounted, manufacturer supplied remote antenna, install the antenna in accordance with the manufacturer's installation instructions. Ensure that the antenna and associated cable will not interfere with the pilot's vision, aircraft controls or displays, or pilot/passenger egress.~~

A13.5.8 If installing an external GNSS position source dedicated to the ADS-B system, install the GNSS position source in accordance with the applicable requirements of Appendix 4.

A13.5.9 If an existing altitude encoder is to be removed:

- (a) Open the encoder circuit breaker or remove the encoder fuse, as required, to isolate power from the existing encoder.
- (b) Remove the existing encoder, mounting provisions, and static connections as required. Ensure any unused static lines are blanked and stowed in such a manner so as to prevent a new low point being introduced in the aircraft static system.

A13.5.10 Install the altitude encoder as follows:

- (a) If the encoder is being installed in a new location, determine a suitable location for the encoder. The encoder should be located in a position which is accessible to the aircraft static lines and will not introduce a new low point in the aircraft static system.
- (b) Install the encoder at the location determined in **sub-section** paragraph A13.4.10(a). The installation is to be carried out in accordance with the manufacturer's installation instructions, the aircraft maintenance manual and the guidelines in FAA AC43.13-1B. The installation should also conform to the following requirements.
 - (1) Manufacturer-supplied or standard parts should be used.
 - (2) The encoder installation should be tested to ensure that the encoder will be restrained throughout the flight envelope.

- (3) Where a modification is required to the aircraft structure to show compliance with **sub-section paragraph** A13.5.10(b)(2), the modification is to be carried out in accordance with the aircraft maintenance manual and the guidelines in FAA AC43.13-1B.
- (c) The encoder is to be connected to the aircraft static system in accordance with the manufacturer's installation instructions using manufacturer-approved connections. No new low point is to be introduced in the aircraft static system.

A13.5.11 Install and placard a suitably rated circuit breaker or fuse.

A13.5.12 Interconnect the transponder, altitude encoder and antenna in accordance with the manufacturer's installation instructions. Wire listed in FAA AC43.13-1B, Chapter 11 or equivalent is to be utilised.

A13.5.13 Replace the access panels removed in **sub-section paragraph** A13.4.2 in accordance with the aircraft manufacturer's maintenance manual.

A13.5.14 Close the transponder and altitude encoder circuit breaker(s) or install the fuse(s).

A13.6 Post-installation testing

A13.6.1 Carry out a leak test of the aircraft static system in accordance with Part 43, Appendix D.1.

A13.6.2 Carry out a functional test of the transponder in accordance with Part 43, Appendix E, and the manufacturer's installation/operation instructions. A functional test of the transponder/altitude encoder system should be carried out in accordance with Part 43, Appendix D.3, Notice of Requirements NTC 91.258, and the manufacturer's installation/operation instructions. Checks are also to be carried out to determine satisfactory operation of all disturbed systems, that there is no interference between avionics systems, no effect on the aircraft compass system and that there is no interference with the aircraft flight controls.

A13.6.3 Verify compliance with both the system configuration and equipment performance requirements of Notice of Requirements NTC 91.258.

A13.7 Manuals

A13.7.1 Generate and issue instructions for continued airworthiness (refer **sub-section paragraph** 14.8).

A13.7.2 Insert the equipment operating instructions in the AFM/POH (refer **sub-section paragraph** 14.9).

A13.8 Certification of release to service

A13.8.1 Amend the aircraft's weight and balance records (refer AC43-2).

A13.8.2 Complete or update electrical load analysis (ELA), retain copy with aircraft and submit copy with documentation (refer AC21-11 & 91-23).

A13.8.3 Amend the aircraft's form CAA 2129, if necessary (refer AC43-10).

A13.8.4 Complete form CAA043-01 *Modification Record*, and process in accordance with **section paragraph** 14 of this AC. Include the statement below along with make, model and serial number of the ramp test set used for the post installation testing must be included in form CAA043-01.

The installed ADS-B OUT system was shown to meet the equipment and performance requirements of CAA NZ Notice of Requirements NTC 91.258.

A13.8.5 Make a certified statement of release to service in accordance with rule 43.105 as well as detailing the work carried out and conformity with Appendix 13 of this AC. Following system performance verification of the ADS-B OUT installation by ground testing, the results of the system performance must be filed in the aircraft maintenance record (evidence of system's performance may be in the form of automated test reports or test equipment screen shots if automated test reports are not available). When system performance is found acceptable, that installer will have to include the following statements in the aircraft maintenance records:

This ADS-B OUT system installation was completed using CAA NZ AC43-14 Appendix 13.

and

The installed ADS-B OUT system was shown to meet the equipment and performance requirements of CAA NZ Notice of Requirements NTC 91.258.

A14. APPENDIX 14—Temporary Mounting of Lightweight Cameras

A14.1 Description

A14.1.1 This appendix describes acceptable technical data for internal or external installation of lightweight cameras on a temporary basis.

A14.1.2 The practice of mounting cameras to aircraft introduces a hazard of camera detachment that may cause aircraft damage, hazard to third parties on the ground, or hazard to the aircraft occupants in the event of an emergency landing, during manoeuvres, or by jamming controls.

A14.2 Applicability & limitations

A14.2.1 This appendix is limited to VFR operations, and it excludes operations for 'hire and reward'.

A14.2.2 Installation of each camera and mounting provision is limited to a combined weight of less than 300g; and frontal area of less than 30cm². Frontal area is the area of the camera and mount as projected from the front of the aircraft.

A14.2.3 The installation is temporary and time limited to two calendar days unless it complies with **sub-section paragraph** 14.5.3.

A14.2.4 All limitations of **sub-section paragraph** 2.1 apply, with the exception that this appendix is limited to all unpressurised aircraft with maximum take-off mass of less than 2000kg and a passenger seating capacity equal to 2 or less.

A14.2.5 This AC is applicable to installations which are installed on a 'no hazard, no interference' basis where:

- (a) Cameras have GSM transmitting functions disabled.
- (b) Cameras that have transmitting functions should be located in accordance with the guidelines of **section paragraph** 9 in terms of spacing from antennas or avionics equipment.
- (c) Cameras must be self-contained with internal batteries and no external wiring.

A14.2.6 Not applicable to carry-on cameras held in hand by passengers which do not require approval, nor to devices worn by the pilot e.g. helmet mounted cameras.

A14.2.7 **Sections Paragraphs** 1 to 14 of this AC apply.

A14.3 Technical instructions

A14.3.1 Installation and release to service

- (a) Installation and release to service may be performed by an appropriately authorised person in accordance with Part 43.

A14.3.2 Installation

- (a) Ensure the aircraft is safe for servicing.
- (b) All reasonable steps must be taken to reduce the risk of in-flight detachment.
- (c) If the installation cannot comply with this AC or if extensive testing or analysis is required, the modification documentation is to be submitted for approval, using a form CAA337 to a certificated Part 146 design organisation, or to CAA.
- (d) Determine a suitable location(s) for the camera(s) to be installed whether external or internal as follows in **sub-sections** paragraphs 14.3.3 and 14.3.4 (respectively).

A14.3.3 External mounting

- (a) The maximum number of external cameras on each wing and empennage must be 1 each.
- (b) The installer must use their judgement to ensure that the equipment does not present a hazard to the aircraft by its:
 - (1) ability to withstand aerodynamic loads (i.e. robust construction, no loose components)
 - (2) flammability (camera must meet 'CE' or equivalent electrical equipment standard)
 - (3) detachment in flight (such that if it were to detach, it will not cause a hazard to critical parts of the aircraft such as propeller/rotors, engine, empennage, or flight control surfaces and systems)
 - (4) interference with the aerodynamic or flight control characteristics (i.e. not placed in areas which will reduce control authority or on slender structures; not on control surfaces; not on horizontal tail surface; not close to or directly in front of flying controls; not upstream or close to probes such as pitot-static)
 - (5) disruption of engine/propeller/rotor characteristics (mounting must not be in locations where flow into or out of ducts/cowlings/props may be interrupted)
 - (6) disruption of navigation/communication equipment (mounting must be at least 1m away from antennas).
- (c) When the installation is not performed by the pilot, the installer must mount a placard visible to the pilot with the words.

CAUTION: Temporary camera installation may have effects on flight characteristics and performance. VNE 150 KIAS, VFR only.

- (d) Care must be taken to avoid damage to the mounting surface by using an attachment that conforms to the surface contour. Do not mount on fabric surfaces.

A14.3.4 Internal mounting

- (a) The installer must use their judgement to ensure that the equipment does not present a hazard by:
 - (1) obstructing the flight controls and instruments, or pilot's visibility
 - (2) reducing structural capability of mounting provisions
 - (3) interfering with cockpit controls
 - (4) possibility of head-strike on the installed equipment for crew or passengers
 - (5) restricting exits or seats during emergency egress.
- (b) Mounting must be at least 1m away from antennas.

A14.3.5 Acceptable mounting techniques

- (a) The use of suction cups alone are not suitable as pilots have experienced in-flight detachment which may be considered a breach of rule 91.201 *Safety of aircraft*. The change in atmospheric pressure and variability of attachment and quality means that suction cups are not suitable.
- (b) Mounting plates which closely match the surface to which they are to be attached may be used and attached with reinforced pressure sensitive tape of a suitable aviation standard.
- (c) The use of proprietary self-adhesive mounts or suction cups can be used provided they are installed with a second, independent means of attachment such as a lanyard/strap or reinforced pressure sensitive tape of a suitable aviation standard.
- (d) Parts of the camera that could detach such as battery compartments must be taped over.
- (e) Rigid mounting extensions should not exceed 5cm in length.
- (f) The structural integrity of the aircraft must not be compromised by the installation.

A14.4 Post-installation testing

A14.4.1 The installation is to be carried out in accordance with any requirements of the manufacturer's installation instructions, the aircraft maintenance manual and the guidelines in FAA AC43.13-1B.

A14.4.2 The installation and any secondary means of attachment must be tested to ensure that it will be restrained throughout the flight envelope to the following loads using a "pull test" with a calibrated spring balance. The load must be maintained for at least 3 seconds without significant deflection or permanent deformation of any part of the mount or permanent loosening/shifting.

(a) **External mounting test loads (to be applied at the centre of the camera):**

- (1) 3kg forwards
- (2) 2kg rearwards
- (3) 3kg upwards
- (4) 3kg downwards
- (5) 1kg port
- (6) 1kg starboard.

(b) **Internal mounting test loads (to be applied at the centre of the camera):**

- (1) 4.5kg in the direction of any controls or passenger locations.

A14.4.3 For those cameras with other transmitting functions (e.g. Bluetooth, Wi-Fi), carry out the post-installation EMI/EMC tests.

A14.5 Certification of release to service

A14.5.1 Record this AC appendix as reference and the location, method of attachment, and details of pull test carried out in the aircraft maintenance records.

A14.5.2 Due to the lightweight, temporary nature of this modification, the following are not required:

- (a) Amendment of weight and balance
- (b) Amendment of form CAA 2129
- (c) Amendment of the AFM/POH
- (d) Completion of form CAA043-01 *Modification Record*.

A14.5.3 The 2-day time limitation of the installation may be reset without re-installation by repetition of the mount integrity “pull test” and recording of this in the aircraft maintenance records.

A14.5.4 Make a certified statement of release to service in accordance with rule 43.105, detailing the work carried out and conformity with Appendix 14 of this AC.

A14.5.5 If there are any accidents, incidents or defects as a result of the installation, report them using form CAA005D to CA005@caa.govt.nz.

A15. APPENDIX 15—Installation of a single mount antenna

A15.1 Description

A15.1.1 This appendix describes acceptable technical data for the installation of a single mount antenna.

A15.2 Applicability

A15.2.1 Single mount antenna means an antenna mounting with a single footprint on the airframe and excludes a wire antenna used for HF and/or ADF-Sense.

A15.2.3 Sections 1 to 14 of this AC apply.

A15.3 General

A15.3.1 If available, follow the instructions provided by the antenna manufacturer, aircraft manuals and the manual of the equipment to be associated with the antenna. Only follow the antenna manufacturer's instructions and recommendations when they are not contrary to the instructions of the aircraft manufacturer.

A15.3.2 Where instructions are otherwise not available, the technical instructions in this appendix provide acceptable technical data for non-pressurised aircraft.

A15.4 Technical instructions

A15.4.1 Ensure the aircraft is safe for servicing.

A15.4.2 Open circuit breakers or remove fuses as required to isolate power from the system(s) to be replaced.

A15.4.3 Remove access panels, etc. as required in accordance with the aircraft manufacturer's maintenance manual.

A15.4.1 Structural Support

A15.4.1.1 The installation must not modify any primary structural elements or affect structure that is listed in the airworthiness limitations of the Instructions for Continued Airworthiness.

A15.4.1.2 Install the equipment in accordance with the requirements and test loads in section 7 Equipment Installation. In addition, it is important to understand the operational characteristics of the aircraft and consider forces that occur during flight as well as those that occur when the aircraft is not in motion (dynamic and static loading).

Antenna drag loads may be calculated with the following formula:

$$D=0.000327 A.V^2 \quad \text{where}$$

D is the drag load on the antenna in lbs.

A is the area of the antenna exposed to the direction of travel of the aircraft in square feet

V is the V_{NE} of the aircraft in mph

Note: The formula includes a 90 percent reduction factor for the streamline shape of the antenna.

Example: a GNSS antenna with a frontal area of 0.014 sq ft. on an aircraft with a V_{NE} of 180Kts (207 mph)

$$D=0.00327 \times 0.014 \times 207^2$$

$$D=0.00327 \times 0.014 \times 42.849$$

$$D=1.96 \text{ lbs}$$

A15.4.1.3 Additionally, an ELT antenna should be capable of supporting a 100 G load in the plus and minus directions of the three-principal axis of the aircraft.

A15.4.1.4 The antenna should be mounted on a flat surface. Minor aircraft skin curvature can be accommodated with the use of an appropriate gasket but if gaps over 0.020" appear between the base plate and the mounting surface, use of a mounting saddle is recommended.

A15.4.1.5 Over-torquing of mounting fasteners is not an acceptable means of reducing the gaps between the baseplate and mounting service.

A15.4.1.6 The use of any material not supplied as part of an installation kit, such as shims or doublers, should be the same as that of the mating aircraft structure. Any OEM processes for surface preparation of materials and fasteners should be adhered to in order to prevent corrosion due to dissimilar materials.

A15.4.2 Antenna location and separation

A15.4.2.1 The antenna should be located where it will not interfere with the operation of the aircraft or other systems on the aircraft. This includes visibility and possible imposed shading of aircraft position lighting and beacons.

A15.4.2.2 The antenna should not be located where it can obstruct airflow to areas of the airframe that require airflow. This includes air data sensors and cooling air inlets. Equal care should be taken to not place the antenna in area affected by heated exhaust air from engines as it may damage the antenna.

A15.4.2.3 An antenna may accumulate ice; therefore, consideration should be given to avoid a location that is forward of any part of the airframe that may be damaged by ice departing the antenna.

A15.4.2.4 The antenna should be located on the aircraft in such a way that there is an unobstructed line-of-sight view of the transmitted or received signals.

A15.4.2.5 The antenna should be separated as far as possible from interference sources such as but not limited to, other radiating antennas, and ignition noise sources. The minimum separation between antennas differs with the function and style of the antenna and its associated equipment. When provided follow the instructions of the antenna and associated equipment manufacturer, if the minima between recommendations differ, use the greater of the provided minima.

Note: An often-used rule of thumb is 90 cm separation between antennas, however applying this rule may lead to real-estate issued on the airframe. Additionally, with increasing transmit power of some systems 90 cm may in some cases not be sufficient. A certificated Part 146 design organisation may be able to substantiate an antenna location if prescribed minima cannot be complied with (e.g. due to proximity with existing antenna).

A15.4.2.6 Antenna locations must be such that they can accommodate the antenna cable loss requirements of the associated equipment. Where possible antenna cables of duplicate systems should not be run together to avoid common failure points.

A15.4.2.7 An ELT/AELS antenna or VHF COM primary antenna (usually VHF COM 1) should be mounted on top of the fuselage as it provides the best unobstructed location. To maintain suitable separation, it is common for the VHF COM secondary antenna to be mounted at the bottom of the fuselage, but this is not a requirement.

A15.4.2.8 An ELT or VHF COM antenna should be located so as to be vertically polarised.

A15.4.2.9 An ELT antenna location must ensure that the routing of the ELT transmitter-to-antenna coaxial cable does not cross any fuselage production joints and should avoid any other location where a transverse separation is likely.

A15.4.2.10 An ELT antenna should be located as close as possible to the ELT transmitter and preferably where the aircraft structure can provide some protection (particularly the antenna base) during a crash sequence (to maintain minimum antenna cable length per ELT manufacturer installation instructions, service loops in the antenna cable are permitted where bend radii are maintained).

A15.4.2.11 When installing an antenna near a structural element, take care to avoid the structure shrouding the antenna or causing excessive voltage standing wave ratio (VSWR) degradation.

A15.4.2.12 If the antenna is mounted internally in the aircraft, the antenna is to be insulated from metal parts and exposed to an 'electronic' window of at least 0.3 m (1 foot) square.

A15.4.3 Bonding and ground plane

A15.4.3.1 As most antennae rely on a bonding to a ground plane for correct operation. In metal-skin aircraft the ground plane is provided by the aircraft skin, in composite aircraft or when mounted on composite panels a ground plane may need to be provided as part of the installation.

A15.4.3.2 For proper antenna bonding refer to the antenna installation instructions. If no specific value is given in the installation instructions or the aircraft maintenance manual, a bonding with a resistance of less than 0.003 Ohm should be achieved. The bonding should be measured with a milliohm meter, conventional multi-meters do not provide the required accuracy.

A15.4.3.3 When the antenna is mounted to a surface not able to provide the required electrical conductivity to produce a ground plane, a ground plane must be provided.

A15.4.3.4 The size of the required ground plane is dependent on the antenna used and the frequency range it caters for. If no specific details are provided in the antenna installation manual, the ground plane should be a quarter wavelength of the lowest frequency in diameter.

A15.4.3.5 The wavelength in meters can be calculated by dividing the speed of light (C) by the frequency (f). To get close approximation to determine the required ground plane 300 divided by the frequency in MHz can be used for the wavelength in meters. Or 984 divided by the frequency in MHz can be used for the wavelength in feet.

Note: the approximate calculations, will give a wavelength approximation that is greater than the actual wavelength, which will benefit the ground plane to the antenna.

A15.4.3.6 A solid plate of conductive material is the best material to use for a ground plane but this is not always practical. Alternatively wire mesh or heavy copper or aluminium foil may be used. In all cases the electrical continuity from the ground plane to the airframe electrical ground should be provided.

A15.4.3.7 Ensure the ground plane is suitably mounted to the structure. (If the ground plane can move or vibrate it could result in noise in the associated avionics system.)

A15.4.4 General installation instructions

A15.4.4.1 When replacing an antenna, it is important to ensure the replacement antenna uses the existing mounting holes. Any holes not reused must be repaired to return the location to its design strength. The repair of these existing holes is not covered by this AC.

A15.4.4.2 The use of a structural backing plate (doubler) is recommended. Backing plates strengthen the immediate point of attachment but if they are not attached to load carrying structure, they do not provide structural support.

A15.4.4.3 Provide an environmental seal around the mating surface of the antenna, unless otherwise specified by the antenna manufacturer or aircraft manual, use an RTV silicone adhesive sealant. On top mounted antennas, fill up the screw holes until flush with the antenna mount to prevent standing water accumulating.

A15.4.4.4 Close the circuit breakers or reinstall the fuses removed in sub-section A15.4.

A15.5 Post-Installation testing

A15.5.1 Carry out a VSWR test after installation. The VSWR should be less than specified in the installation documentation, but if not specified should be less than 2:1 and must not exceed 3:1.

A15.5.2 Carry out a functional test of the affected system in accordance with the manufacturer's installation/operations manual to determine satisfactory operation of the installed equipment. Checks are also to be carried out to determine satisfactory operation of all disturbed systems, that there is no interference between avionics systems, that there is no effect on the aircraft compass system and that there is no interference with the aircraft flight controls.

A15.5.3 For aircraft approved for night operations, ensure that the aircraft lighting is unaffected and that there are no unwanted reflections present.

A15.6 Manuals

A15.6.1 Generate and issue instructions for continued airworthiness (refer sub-section 14.8).

A15.7 Certification and release to service

A15.7.1 Amend the aircraft's weight and balance records (refer AC43-2).

A15.7.2 Make a certified statement of release to service in accordance with rule 43.105, detailing the work carried out and conformity with Appendix 15 of this AC.

A16. APPENDIX 16—Installation of replacement LED lights

A16.1 Description

A16.1.1 This appendix describes acceptable technical data for the installation of LED lights as replacements for conventional incandescent lamps for anti-collision lights, position lights, landing & taxi lights, and cabin and cockpit conventional lights.

A16.2 Applicability & limitations

A16.2.1 All limitations of sub-section 2.1 apply.

A16.2.2 Sections 1 to 14 of this AC apply.

A16.2.3 This appendix does not apply to aircraft with NVIS.

A16.3 General

A16.3.1 LED lights refer to lights that utilise Light Emitting Diodes as their source of light. They are typically more efficient (consume less power for given intensity output), have a much longer life, and are more rugged than conventional incandescent light bulbs.

A16.3.2 Replacement LED Lights must:

- (a) perform an identical function to the lights being replaced
- (b) not alter the existing approved aircraft maintenance requirements
- (c) be of an equivalent approval level as defined in Part 91, Appendix A.6
- (d) be specified by the equipment manufacturer as being a direct replacement for the lights being removed.

A16.3.3 Replacement LED Lights must utilise where applicable the existing:

- (a) mounting provisions
- (b) wiring
- (c) interface with existing systems

A16.4 Technical Instructions

A16.4.1 Ensure the aircraft is safe for servicing.

A16.4.2 Open circuit breakers or remove fuses as required to isolate power from the system(s) to be replaced.

A16.4.3 Gain access as required in accordance with the aircraft manufacturer's maintenance manual.

A16.4.4 Verify that the circuit breaker or fuse rating from the lights to be removed is appropriate for the new LED lights. Notwithstanding sub-section A16.3.1

above, if the fuse or circuit breaker rating is not appropriate for the new LED Light, the modification is no longer capable of approval under the provisions of Appendix 16 of this AC.

A16.4.5 Remove the light(s) to be replaced in accordance with the aircraft manufacturer's maintenance manual. Existing associated wiring and mounting provisions are to be retained.

A16.4.6 If any modification of electrical wiring is to be performed, it must be in accordance with acceptable practices such as, in the first instance, the aircraft maintenance manual and the LED manufacturer's information. If that is not available, then Chapter 11 of FAA Advisory Circulars AC 43.13-1B may be used. For anti-collision lights, additional guidance may be sought from Chapter 4 of FAA AC 43.13-2B.

A16.4.7 If any structural modification is required to mount the LED Lights, reference must be made to FAA AC 43.13-2B.

A16.4.8 Install the replacement LED lights in accordance with the manufacturer's installation instructions and the aircraft maintenance manual in the space vacated in sub-sections A16.4.5. Where applicable, the previously retained mounting provisions are to be utilised.

A16.4.9 Close the access previously gained in accordance with the aircraft manufacturer's maintenance manual.

A16.4.10 Close the circuit breakers or reinstall the fuses removed in sub-sections A15.4.2.

A16.5 Post-Installation testing

A16.5.1 Carry out a functional test of the installed LED Lights and all other disturbed systems in accordance with the applicable Part 43 and the manufacturer's installation/operation instructions (refer sub-sections 13.1 and 13.2).

A16.5.2 Carry out an EMI/EMC functional check to ensure that there is no interference between the new LED Lights and other aircraft systems, that there is no effect on the aircraft compass system and that there is no interference with the aircraft flight controls (refer sub-section 13.3).

A16.6 Manuals

A16.6.1 If applicable generate and issue instructions for continued airworthiness (refer sub-section 14.8).

A16.6.2 Insert the equipment operating instructions in the AFM/POH (refer sub-section 14.9).

A16.7 Certification and release to service

A16.7.1 Amend the aircraft's weight and balance records per section 11 of this AC.

A16.7.2 Complete or update the aircraft's electrical load analysis (ELA), retain copy with aircraft records.

A16.7.3 Make a certified statement of release to service in accordance with rule 43.105, detailing the work carried out and conformity with Appendix 16 of this AC.

A17. APPENDIX 17—Installation of supplemental electronic carbon monoxide (CO) detectors

A17.1 Description

A17.1.1 This appendix describes acceptable technical data for installation of supplemental electronic carbon monoxide detectors.

A17.2 Applicability & limitations

A17.2.1 All limitations of section 2 of this AC apply, supplemented by the following:

A17.2.2 Carbon monoxide detectors installed under the provisions of this appendix must comply with one of the following:

- (a) TSO-C48()
- (b) ETSO-C48
- (c) ETSO-2C48a, or
- (d) Have a Letter of Approval in accordance with FAA policy PS-AIR-21.8-1602 (NORSEE).

A17.2.3 The system must not be installed such that it interferes with the functioning of the flight controls.

A17.2.4 The mounting of the carbon monoxide detector must be on fixed surfaces of the aircraft i.e. not on any control system components that are subject to motion.

A17.2.5 The system limitations as defined by the carbon monoxide detector manufacturer must be followed.

A17.2.6 Where the limitation of the system manufacturer is less restrictive than a limitation in this AC, the limitation of the AC applies.

A17.2.7 Electronic carbon monoxide detectors that have additional functions and or features are not eligible for installation using this AC with the exception of:

- (a) Chronograph/flight timer where this function does not require additional interfacing or power connection.
- (b) Cabin pressure warning where this function does not require additional interfacing or power connection.

A17.2.8 The carbon monoxide detector may be interfaced per manufacturer instructions to existing external avionics systems for the sole purpose to provide alert and warning annunciations.

A17.2.9 Any maintenance action required to enable carbon monoxide related annunciations on external avionics systems is out of scope of this AC and must be performed in accordance with the ATD related to the installation of the external

equipment (this includes software updates and/or system configuration that is not normally accessible to the pilot).

A17.3 Technical Instructions

A17.3.1 Ensure the aircraft is safe for servicing.

A17.3.2 Remove access panels etc. as required in accordance with the aircraft manufacturer's maintenance manual.

A17.3.3 Install the electronic carbon monoxide detector in accordance with the equipment manufacturer's installation instructions.

A17.3.4 Unless otherwise noted in the manufacturer's installation instructions, install the electronic carbon monoxide detector as follows:

- (a) Install the carbon monoxide detector in a position that ensures correct and timely detection of carbon monoxide present in the cockpit. Ensure any associated warning annunciations are visible in the primary field of view and that any associated controls are accessible to the pilot from their normally seated position, ensuring it does not obstruct their view of primary flight instruments and annunciators.
- (b) Install the equipment in accordance with the requirements and test loads in section 7 Equipment Installation.

A17.3.5 Install and placard a suitably rated circuit breaker or fuse.

A17.3.6 Replace the access panels removed in sub-section 3.2 in accordance with the aircraft manufacturer's maintenance manual.

A17.4 Post-Installation testing

A17.4.1 Carry out post installation functional checks per the manufacturer's installation instructions and section 13 of this AC.

A17.5 Manuals

A17.5.1 Generate and issue instructions for continued airworthiness (refer section 14.8).

A17.5.2 Insert the equipment operating instructions in the AFM/POH (refer section 14.9).

A17.6 Certification and release to service

A17.6.1 Amend the aircraft's weight and balance records per section 11 of this AC.

A17.6.2 Record any required calibration/overhaul of the carbon monoxide detector in the appropriate section of the aircraft logbook (many electronic carbon

monoxide detectors have a 7-year recalibration to be carried out by the equipment manufacturer).

A17.6.3 Complete or update the aircraft's electrical load analysis (ELA), retain copy with aircraft records.

A17.6.4 Make a certified statement of release to service in accordance with rule 43.105, detailing the work carried out and conformity with Appendix 17 of this AC.

A18. APPENDIX 18—Installation of Angle of Attack (AoA) Sensors for awareness only

A18.1 Description

A18.1.1 This appendix describes acceptable technical data for installation of supplemental Angle of Attack (AoA) systems.

A18.2 Applicability & limitations

A18.2.1 All limitations of section 2 of this AC apply, supplemented by the following:

A18.2.2 Applicable to fixed-wing aeroplanes only.

A18.2.3 Applicable only to AoA systems that:

- (a) Have an FAA letter of approval in accordance with FAA policy AIR100-14-110-PM01; or
- (b) Have an FAA letter of approval in accordance with FAA policy PS-AIR-21.8-1602 (NORSEE); or
- (c) Have a declaration of compliance with the ASTM F3011-13 Standard issued by the manufacturer of the AoA system to be installed.

A18.2.3 The system must be a stand-alone AoA system:

- (a) The system may must not interface with, or rely on, the aircraft pitot-static system
- (b) If the AoA system uses a heated probe, the heating circuit must remain independent of the aircraft pitot, static, and stall warning heating system
- (c) The system must not be used as an input to any other system, such as an AFCS, Stick pusher, envelope protection or comparable function etc., and
- (d) The system must not be installed such that it interferes with the functioning of the flight controls, pitot-static system, stall warning system, or previously installed AoA system.

A18.2.4 Systems installed per this appendix are supplemental, they must not to replace the aircraft certificated AoA system. (This includes using the system as relief on an MEL where applicable).

A18.2.5 The AoA system calibration instructions must include a test that after calibration of the AoA system, the AoA does not provide information conflicting with the stall warning from a certified stall warning system, if the aircraft is so equipped.

A18.2.6 The limitations as defined by the AoA system manufacturer must be followed. Where the limitation of the system manufacturer is less restrictive than a limitation in this AC, the limitation of this AC applies.

A18.3 Technical Instructions

A18.3.1 Ensure the aircraft is safe for servicing.

A18.3.2 Remove access panels etc. as required in accordance with the aircraft manufacturer's maintenance manual.

A18.3.3 Install the Supplemental AoA System in accordance with the equipment manufacturer's installation instructions.

A18.3.4 Unless otherwise noted in the manufacturer's installation instructions, install the AoA system as follows.

- (a) Install the **AoA indicator** in a position that is visible and accessible to the pilot from their normally seated position, ensuring it does not obstruct their view of primary flight instruments and annunciators.
- (b) Install the **AoA probe** on a suitable external location where it does not interfere with flight controls, pitot-static and stall warning systems. Installation of the probe on an inspection panel is preferred where possible.
- (c) Install the equipment in accordance with the requirements and test loads in section 7 Equipment Installation. In addition, it is important to understand the operational characteristics of the aircraft and consider forces that occur during flight as well as those that occur when the aircraft is not in motion (dynamic and static loading).

Drag loads may be calculated with the following formula:

$$D=0.000327 A.V^2 \quad \text{where}$$

D is the drag load on the probe in lbs.

A is the area of the probe exposed to the direction of travel of the aircraft in square feet

V is the V_{NE} of the aircraft in mph

Note: The formula includes a 90 percent reduction factor for the streamline shape of the probe.

Example: a probe with a frontal area of 0.014 sq ft. on an aircraft with a V_{NE} of 180Kts (207 mph)

$$D=0.00327 \times 0.014 \times 207^2$$

$$D=0.00327 \times 0.014 \times 42.849$$

$$D=1.96 \text{ lbs}$$

A18.3.5 Install and placard a suitably rated circuit breaker or fuse.

A18.3.6 Replace the access panels removed in section 3.2 in accordance with the aircraft manufacturer's maintenance manual.

A18.3.7 If not already done so per the AoA system equipment manufacturer's installation instructions install a placard near the AoA indicator stating "Not for use as a primary instrument for flight".

A18.4. Post-Installation testing

A18.4.1 Carry out post installation functional checks per the manufacturer's installation instructions and section 13 of this AC.

A18.4.2 If the instructions require calibration of the system to be carried out in flight ensure the aircraft has a suitable release to service prior to carrying out this calibration.

(a) As Calibration of the system is part of the installation, release the aircraft for an operational check flight per Rule 43.103(a)(4)(iii). Refer to Rule 43.103(c) for the correct means of documenting the release to service for an operational flight check.

(b) Carry out the in-flight calibration of the AoA system per the manufacturer's instructions during the operational flight check under Rule 91.613. Carry out this flight with only essential personnel on board the aircraft ensuring control and situational awareness is maintained throughout the flight. (e.g. a Pilot flying and a suitable rated LAME carrying out the unit control needed for calibration).

A18.5 Manuals

A18.5.1 Generate and issue instructions for continued airworthiness (refer section 14.8).

A18.5.2 Insert the equipment operating instructions in the AFM/POH (refer section 14.9).

A18.6. Certification and release to service

A18.6.1 Amend the aircraft's weight and balance records per section 11 of this AC.

A18.6.2 Complete or update the aircraft's electrical load analysis (ELA), retain copy with aircraft records.

A18.6.3 Make a certified statement of release to service in accordance with rule 43.105, detailing the work carried out and conformity with Appendix 18 of this AC.

A19. APPENDIX 19—Installation of ADS-B systems for awareness only

A19.1 Description

A19.1.1 This appendix describes acceptable technical data for installation of ADS-B devices for ADS-B awareness only.

A19.1.2. ADS-B devices in the context of this AC are any device providing an ADS-B related function that does not meet the Part 1 definition of an ADS-B System. This includes ADS-B in receivers, TABS and/or Electronic Conspicuity devices.

A19.1.3. This appendix covers the installation of these devices, the operator must determine if the operation of the device is suitable.

A19.2. Applicability & limitations

A19.2.1 All limitations of section 2 of this AC apply, supplemented by the following.

A19.2.2 The ADS-B device for awareness in addition to ADS-B IN may offer ADS-B out in the form of TABS or Electronic Conspicuity. The ADS-B OUT operation of these devices do not meet the performance requirements as required by rule 91.257 as documented in CAA Notice of requirement NTC 91.258. These devices must not be used as an ADS-B OUT solution to enter controlled airspace unless otherwise authorised or instructed by ATC under the provisions of rule 91.247(a).

A19.2.3 The installation of ADS-B devices in accordance with this appendix does not relieve the operator from the requirements of rule 91.7 for any portable device used in conjunction with the installed ADS-B device.

A19.2.4 The ADS-B device must not be mounted where it obstructs the pilots view from the cockpit.

A19.2.5 ADS-B devices may be connected to other avionic equipment, provided that equipment is listed as an approved model number in the installation manual.

A19.2.6 Suction devices must not be used to mount ADS-B equipment, regardless if they were supplied with the device.

Note: Suction cups are unreliable to retain a device during flight, exposure to sunlight and reducing ambient pressure (decreasing the pressure differential offered by the suction) reduce the performance and provide a hazard to the occupants when the device loses its retention.

A19.3 Technical Instructions

A19.3.1 Ensure the aircraft is safe for servicing.

A19.3.2 Remove access panels etc. as required in accordance with the aircraft manufacture's maintenance manual.

A19.3.3 Install the ADS-B device in accordance with the equipment manufacturer's installation instructions.

A19.3.4 Unless otherwise noted in the manufacturer's installation instructions, install the ADS-B device as follows:

- (a) Install the ADS-B device in a position that ensures that any associated controls are accessible to the pilot from their normally seated position, ensuring it does not obstruct their view of primary flight instruments and annunciators.
- (b) The installation is to be carried out in accordance with the manufacturer's installation instructions please take note of item A19.2.4 above, the aircraft maintenance manual and the guidelines in FAA AC43.13-1B.
- (c) Install the equipment in accordance with the requirements and test loads in section 7 Equipment Installation.

A19.3.5 Install and placard a suitably rated circuit breaker or fuse.

A19.3.6 Replace the access panels removed in sub-section 3.2 in accordance with the aircraft manufacturer's maintenance manual.

A19.4 Post-Installation testing

A19.4.1 Carry out post installation functional checks per the manufacturer's installation instructions and section 13 of this AC.

A19.4.2 During EMC/EMI testing ensure there is an established connection with any portable device intended to be used in conjunction with the ADS-B device. (e.g. if an iPad will be used as the display, ensure the Wi-fi and or Bluetooth connection required is established and traffic, if present, is displayed).

A19.5.Manuals

A19.5.1 If applicable generate and issue instructions for continued airworthiness (refer section 14.8).

A19.5.2 Insert the equipment operating instructions in the AFM/POH (refer section 14.9).

A19.6 Certification and release to service

A19.6.1 Amend the aircraft's weight and balance records per section 11 of this AC.

A19.6.2 Complete or update the aircraft's electrical load analysis (ELA), retain copy with aircraft records.

A19.6.3 Make a certified statement of release to service in accordance with rule 43.105, detailing the work carried out and conformity with Appendix 19 of this AC.